



Article

Non-figurative decorated bronze-sheet artefacts from Veneto region graves dated to the 8th and the 7th centuries BC: typology, chronology, distribution and parallelisms

Vanessa Baratella^{1*}

¹ Dipartimento dei Beni Culturali: Archeologia, Storia dell'Arte, del Cinema e della Musica, Università degli Studi di Padova

Keywords

- Bronze-sheet production
- Early Iron Age
- Pre-Roman Veneto
- Grave goods

Summary

During the 8th and the 7th centuries BC, bronze-sheet artefacts related to the sphere of feasting and drinking are attested in a few graves of ruling elites' members of pre-Roman Veneto. The diffusion of these artefacts, which is known to involve not only the Veneto region and the Italic peninsula, but the whole central and eastern Europe during the Iron Age, testifies the wide-ranging circulation of these objects of high prestige, assumed by the leaders of communities.

The aim of this work is to systematically analyse the typology of bronze vessels and objects linked to the drinking and feasting sphere found in proto-urban Veneto graves and comparing it with the large and well known sample of bronze-sheet productions of the extra-Veneto and European areas, in order to identify analogies and/or differences between the artefacts diffused in different cultural contexts during the same time span, deepening the chronological and distributive reflection connected to this topic.

Parole chiave

- Produzione lamina di bronzo
- Prima Età del Ferro
- Veneto pre-romano
- Corredi funerari

Riassunto

Nel corso dell'VIII e VII secolo a.C., manufatti in lamina di bronzo relativi alla sfera del bere e del mangiare nell'ambito di cerimonie aristocratiche sono attestati in alcune tombe di membri delle élite dominanti del Veneto preromano. La diffusione di questi manufatti, che notoriamente coinvolge non solo il Veneto e la penisola italiana, ma tutta l'Europa centrale e orientale durante l'Età del Ferro, testimonia la circolazione ad ampio raggio di questi oggetti di alto prestigio, assunti dai vertici delle comunità.

L'obiettivo di questo lavoro è quello di analizzare sistematicamente la tipologia del vasellame e degli oggetti in bronzo legati alla sfera del convivio aristocratico rinvenuti nelle tombe venete di fase protourbana e di confrontarla con l'ampio e noto campione di produzioni in lamina di bronzo di area extra-veneta ed europea, al fine di individuare analogie e/o differenze tra i manufatti diffusi in contesti culturali diversi nello stesso arco temporale, approfondendo la riflessione cronologica e distributiva dei manufatti in esame.

* Autore per la corrispondenza:
vanessa.baratella@unipd.it

Redazione: Marco Avanzini, Elisabetta Flor, Valeria Lencioni

pdf: https://www.muse.it/it/Editoria-Muse/Preistoria-Alpina/Pagine/PA/PA_52-2022/PA_52-2022.aspx

Introduction

Bronze-sheet artefacts represent a category of high value and prestige goods featured, above all, in grave goods of high-ranking burials throughout the entire Iron Age in Veneto region. As far as the 8th and 7th centuries BC are concerned, the categories of artefacts involved in the bronze-sheet productions are generally related to the practice of drinking and feasting in aristocratic circles: *situlae* and *ci-stae* for holding liquids, drinking cups, bowls, goblets and strainers.

In literature, many studies dedicated to bronze-sheet artefacts decorated according to the tradition of the *Situla Art* are known; in these works – which involve only artefacts dating from the end of the 7th century BC onwards – many aspects related, above all, to the iconography and semantic meanings of the representations are analysed in detail¹. On the other hand, systematic studies on typological, chronological and distributive aspects of non-figurative decorated bronze-sheet supports are extremely rare and generally concern specific contexts².

With the aim of presenting an overall analysis of these manufacture categories dated between the 8th and the 7th centuries BC – i.e., during the crucial phase of birth and development of protourban centres in Veneto region –, all the artefacts currently known in literature and coming from graves – as known, burials are the most appropriate contexts for a typo-chronological analysis of materials, representing, generally, “closed contexts” – will be examined, providing a typological classification, a chronological framework, an analysis of distribution and a comparison with the main productions from Central and Eastern Europe.

Materials and methods

The entire Veneto region is interested during the Iron Age by a uniform cultural aspect with some local distinct features. The evidences examined in this paper comes exclusively from graves or form contexts that are recognised as “grave contexts” basing on the nature of the findings, even without exhaustive excavation or bibliographical information, as the case of Rivoli Veronese (Verona), Padova-Borgo Santa Croce or Colognola ai Colli (Verona)³.

Most of the evidence are distributed in some of the main centres of Pre-Roman Veneto region, i.e., Este (Padova), Padova itself and Montebelluna (Treviso), to which could be added the punctual findings of Rivoli Veronese (Verona) and Colognola ai Colli (Verona), as shown in Fig. 1.

The centre of Este represents the site where most of the artefacts come from, but this data is closely connected to the state of publication of Veneto cemeteries: a large number of graves dated to the 8th and 7th centuries BC found in Este necropolis, approximately more than 150, are published to date and so, available for different analysis; in contrast, most of the graves of this chronological phase from other sites of Veneto are unreported to date⁴. An exception is represented by the case of Padova, where almost 90 graves dated to the 8th and the 7th centuries BC are published⁵, but the percentage of graves dated to the 7th century BC compared to those referable to the 8th century BC is significantly lower and therefore statistically under-represented compared to the more homogeneous situation of Este.

The analysed artefacts belonging to the following graves, enunciated according to the provenience contexts:

Este (PD) (Fig. 1, n. 1):

Northern necropolis: Casa di Ricovero, graves 155, 160, 234, 235, 236 (Chieco Bianchi & Calzavara Capuis 1985: 110-116; 125-131; 187-195; 294-300; 300-312). Villa Benvenuti, graves 89; 122; 277; 278 (Capuis & Chieco Bianchi 2006: 156-158; 267-276; 333-339; 342). Fondo Rebato, grave 187 (Frey 1969: Tab. 11). Fondo Candeco, grave 307 (Stjernquist 1967: Tab. IV).

Southern necropolis: Fondo Randi, grave 14 (Frey 1969: Tab. 2).

Padova (Fig. 1, n. 2):

Eastern necropolis: Via Tiepolo-San Massimo, “Tomba dei Vasi Borchiati” (Gamba et al. 2011).

Southern necropolis: Palazzo Emo Capodilista-Tabacchi, grave 318 (Pirazzini 2005: 157).

Borgo Santa Croce: sporadic find (Cupitò 2004).

Montebelluna (TV) (Fig. 1, n. 3):

Posmon necropolis, graves 3; 54 (Manessi & Nascimbene 2003: 157-161; 127-137).

Colognola ai Colli (VR) (Fig. 1, n. 4):

sporadic find (Salzani 1983).

Rivoli Veronese (VR) (Fig. 1, n. 5):

Castello di Rivoli, “Tomba del Signore” (Cupitò 2017).

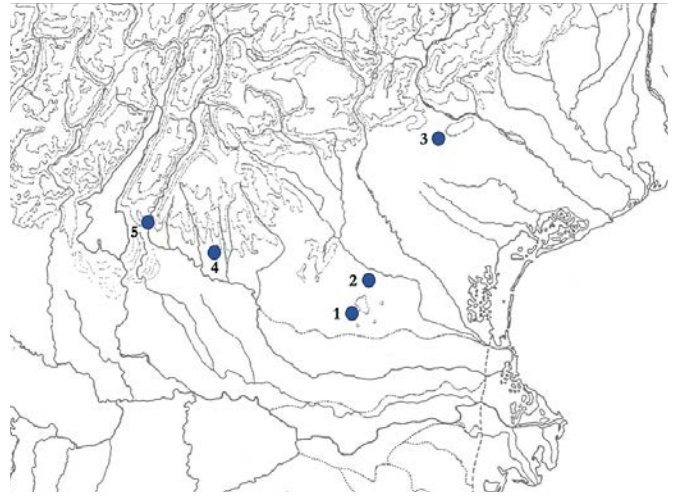

Fig. 1: Localisation of the sites with evidence of bronze-sheet artefacts here analysed: 1. Este (PD); 2. Padova; 3. Montebelluna (TV); 4. Colognola ai Colli (VR); 5. Rivoli Veronese (VR). / Localizzazione dei siti dai quali provengono i manufatti in lamina di bronzo analizzati: 1. Este (PD); 2. Padova; 3. Montebelluna (TV); 4. Colognola ai Colli (VR); 5. Rivoli Veronese (VR).

¹ Among the extended literature that has dealt with this topic, see, above all Frey 1969; Turk 2005; Sassatelli 2013 – in this volume there are also several catalogue entries that discuss specifically some fundamental artefacts (Gamba et al. 2013) –.

² An overall review of bronze vessels from the Alpine area of Golasecca culture has been published in 2009 by R.C. de Marinis (de Marinis 2009).

³ Circumstances of discovery/excavation of these specific contexts will be discussed in the following dedicated insights.

⁴ In the examined area, cemeteries with burials ascribed to the 8th and the 7th centuries BC are as follows: Montagnana (PD), 2 graves dated to the 8th and the 7th centuries BC published to date (Bianchin Citton et al. 1998); Garda (VR), 1 grave dated to the 8th and the 7th centuries BC published to date (Salzani 1984); Lovara di Villabartolomea (VR), 1 grave dated to the 7th century BC published to date (Malnati 2002); Gazzo Veronese (VR), 7 graves dated to the 8th and the 7th centuries BC published to date (Belluzzo & Salzani 1996: 291-293; Salzani 2001; Salzani 2005); Oppeano (VR), 11 graves dated to the 8th and the 7th centuries BC published to date (Salzani 2018); Altino (VE), 1 grave dated to the 7th century BC published to date (Gambacurta 2011); Montebelluna (TV) cemeteries – Posmon and Santa Maria in Colle nucleus, 16 graves dated to the 8th and the 7th centuries BC published to date (Manessi & Nascimbene 2003); San Vito al Tagliamento (PN), 32 graves dated to the 8th century BC published to date (Cassola Guida 1978); Montereale Valcellina (PN), 2 graves dated to the 8th and the 7th centuries BC published to date (Vitri 1996).

⁵ For the edition of these graves, see: Zampieri 1975; AA.VV. Padova preromana 1976; Gamba et al. 2014.

Artefact categories subjected to typological and comparative analysis are, as follows:

- *Situlae*: 13
- "Amphorae": 1
- *Cistae*: 4
- Cups: 6
- *Lebetes*: 3
- Basins: 2
- High foot goblets: 1
- Cup-strainers: 3
- *Simpula*-Ladles: 8

Typological classification is conformed the traditional method developed by Renato Peroni and collaborators (Peroni 1994, Peroni 1998), with some specific adjustments due to the nature of the sample. A Type, a series of artefacts marked by a recurring association of attributes, could be articulated in "Varieties" – i.e., recurrent variations in a type but still compatible with the structure of the common model – and could have some "Variants", artifacts deviating, in one or more attributes, from the original type. An artifact not included in any encoded type is classified as "*Unicum*".

Once obtained the typological structure, the main comparisons are identified according to the known bibliography. The parallelisms are sought both in Italy and Europe: fundamental have been the volumes of the series "Prähistorische Bronzefunde" (Patay & Petres 1990; Kytlicová & Siegfried Weiss 1991; Prüssing 1991; Novotná 1991; Jacob 1995; Gedl 2001; Martin 2009; Jereb 2016) and the typological classification of bronze *cistae* edited by Berta Stjernquist "*Ciste a cordoni (Rippenzisten). Produktion, unktion, diffusion*" (Stjernquist 1967). In addition to these works, the entire recent bibliography on bronze-sheet production from Italian and Central and Eastern European contexts has been considered.

Chronological observations, finally, outcomes from a global remark of the grave goods composition and the set of comparisons.

Results - *Situlae*

The sample of examined *situlae* counts 13 specimens. Three of these are fragmented while the remaining 10 can be examined in their entirety.

Situlae with fixed handles

The first type of *situla* analysed, **Sit_1** (Fig. 2, n. 1), has only one attestation in the area in exam that came from the eastern necropolis of Via Tiepolo-San Massimo in Padova, specifically from "Tomba dei Vasi Borchiatii" (Gamba et al. 2011: 79, n. 1, tab. 1), an élite grave dated – basing on the grave goods – to last decades of the 8th /beginning of the 7th century BC. This *situla* housed the ceramic ossuary with the cremated remains, its lid and a bronze cup⁶.

Morphologically, the upper part of the *situla* consists of a single sheet joined with a series of rivets while the lower part of the vessel is formed by a second shorter sheet, fixed, as is the bottom, again with rivets.

The *situla* has a tronco-conical profile and a distinct neck, the rim is folded and the shoulder is keeled; a thin rib is placed between the shoulder and the neck. Three banded handles are set between the rim and the shoulder, fixed with three flat rivets; the handles are decorated with a double row of longitudinal small studs on the band, while the upper part shows three circular studded motifs surrounded by small studs.

This *situla* belongs to the widely documented *Kurd* type, codified by Gero von Merhart in 1952 (von Merhart 1952: 29-33) and repeatedly referred to in the later literature. The distribution area of the type involves the north-alpine area, Netherlands, France, Czech Republic, the Carpathian basin and the Italian peninsula, where

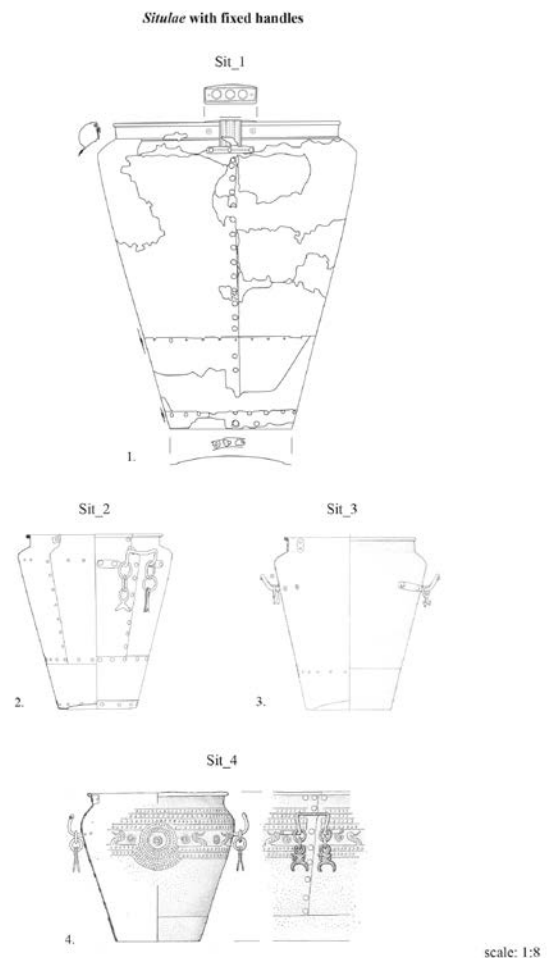

Fig. 2: Types of *situlae* with fixed handles here identified: 1. "Tomba dei Vasi Borchiatii", Via Tiepolo-San Massimo cemetery, Padova; 2. Grave 236, Casa di Ricovero cemetery, Este (PD); 3. Grave 277, Villa Benvenuti cemetery, Este (PD); 4. "Tomba del Signore", Rivoli Veronese (VR). / I tipi di situle a manici fissi identificati: 1. "Tomba dei Vasi Borchiatii", cimitero di via Tiepolo-San Massimo, Padova; 2. Tomba 236, Cimitero Casa di Ricovero, Este (PD); 3. Tomba 277, cimitero di Villa Benvenuti, Este (PD); 4. "Tomba del Signore", Rivoli Veronese (VR).

several examples from Etruria, northern Lazio, Trentino, Lombardia and Veneto regions are recorded (Dehn et al. 2005: 148-149; Egg & Kramer 2016: 97-102).

Kurd-type *situlae* are widespread between the end of the Bronze Age and their production follows on, with some adaptations, during the Early Iron Age (von Merhart 1952: 31-32; Prüssing 1991: 52; Dehn et al. 2005: 147-155). According to the latest revision of R. Dehn, M. Egg and R. Lehnert on *Kurd*-type *situlae*, Iron Age specimens are characterised by a slimmer profile than *Urnfelder* vessels, a sloping shoulder, the rim generally folds over a core of metal material and the lower part of the vessel is always secured to the body with a series of rivets (Dehn et al. 2005: 150-151).

Two subgroups within the type can also be distinguished according to the different production areas, namely the group of *situlae* produced "North of the Po River" and those produced "South of the Po River"; the two groups have some morphological differences especially regarding the overall vessels profile, specifically, the *situlae* found in the area south of the Po River show a squatter profile and a less careful manufacture. As shown by R. Dehn and collaborators, most of the *Kurd situlae* found in Italian contexts, both south and north of the Po River, can be dated between the last quarter of the

⁶ For the cup, see below "Cup_1b".

8th century BC and the transition to the 7th century BC (Dehn et al. 2005: 149-151).

Kurd Iron Age *situlae* belonging to “North of the Po River” production group, among which the specimen of “Tomba dei Vasi Borchiatii” can be included, generally have an angular shoulder and a highly developed body in height exceeding 40 centimetres (de Marinis 2009: 178).

The *Kurd* type artefacts show a modest range of internal variability, so is possible to compare, for the general profile – as already proposed by R.C. de Marinis (de Marinis 2009: 178) –, the “Tomba dei Vasi Borchiatii” specimen to the *situla* from grave 696 in Hallstatt cemetery (Prüssing 1991: 51, n. 106, tab. 21) – a burial dated to Ha D2 phase, even if with some chronological doubts (above all, Peroni 1973: 40) – and to some *situlae* from the Balkan area, from Most na Soči cemetery graves 1166 and 1469 (Jereb 2016: 26-27, n. 14, tab. 13; n. 15, tab. 14) dated, respectively, to the 8th century BC and to Ha D2-D3 (end of the 6th/beginning of the 5th century BC), and Magdalenska gora tumulus 4/1 (Jereb 2016: 26, n. 13, tab. 12), dated to Ha C1-C2, the middle of the 7th century BC.

The Hallstatt 696 *situla*, and in general the Eastern tradition *situlae*, however, compared to the Padova example, always present three ribs between the neck and shoulder and a generally narrower banded handle. In any case, with the Hallstatt *situla*, “Tomba dei Vasi Borchiatii” vessel shares the same lengthened tronco-conical profile, the three-sheets structure and also the general conformation of the handles.

Even if less punctual, another comparison come from Hallein cemetery, grave 73, dated to Ha D2, beginning of the 6th century BC, (Prüssing 1991: n. 105), but this exemplar differs from Vasi Borchiatii and Hallstatt *situlae* for the handles, simpler, smaller and not decorated.

“Tomba dei Vasi Borchiatii” *situla* is characterised by the presence of three banded handles: this detail could be compared with a few other specimens in the entire sample of *Kurd* type *situlae*, in specific with the above mentioned grave 1166 from Most na Soči cemetery – as already underlines by Gamba & Gambacurta in 2011 – and with Kleinklein-Pommerkogel *situla* (Egg & Kramer 2016: 95, fig. 38), that shows also the same decoration pattern with rows of longitudinal small studs on the band⁷. Kleinklein-Pommerkogel is dated to Ha C2, about to the middle/second quarter of the 7th century.

Finally, even though the *Kurd situla* from the Second Warrior's Grave at Sesto Calende (de Marinis 2009) shows a figurative decoration made with embossed little dots, its overall structure is quite similar to that of Padova: the rim has a short volute, the neck is not particularly developed and only one rib between the neck and the shoulder is placed. Two *laminae* make up the body of the *situla*, while the bottom is blocked to the second sheet by a series of rivets. The Second Warrior's Grave of Sesto Calende is assigned to the first phase of the Golasecca II by R.C. de Marinis, i.e., at the end of the 7th century BC; the Sesto Calende area represents, according to the literature (among the latest reflections on this topic, see Egg & Kramer 2016: 102) a specific centre of production and elaboration of a Variant of *Kurd* traditional type.

The second type individuated, **Sit 2** (Fig. 2, n. 2), correspond to Este, Casa di Ricovero grave 236 *situla* (Chieco Bianchi & Calzavara Capuis 1985: 302, n. 1, tab. 204), a vessel used as ossuary for a man's high-ranking deposition⁸ dated, basing on the grave goods, to the middle of the 8th century BC (Chieco Bianchi & Calzavara Capuis 1985: 309-311).

Also in this case, the type has only one attestation in the entire Veneto region, but find some parallels in North Alpine panorama.

This *situla* has a tronco-conical profile, the upper part is com-

posed of two sheets joined with rivets followed below by a second, shorter sheet; the bottom of the vessel is shaped by a fourth, smaller, sheet with a slight concavity, secured to the body of the vessel with rivets. The rim of the *situla* is folded, the shoulder is high and rounded and two transverse handles fixed with two pairs of nails are attached on it; the handles, made by a round bar that are shaped with an almost rectangular curve, end in a flat, long plaque. From each handle hang two rings with double dovetail pendants.

Casa di Ricovero 236 *situla* could be compared to a type of vessels codified by G. Prüssing in 1991 for Austrian area as “nachfolger der Eimer von Typ Hajdüböszörmény” (Prüssing 1991: 52-54), i.e., a type of *situlae* subsequent to Hajdüböszörmény exemplars. This type shows a general tronco-conical profile, in common with the *Kurd*-type, but, overall, shares various peculiar attributes with the *Hajdüböszörmény* traditional type.

General attributes of the “nachfolger der Eimer von Typ Hajdüböszörmény” type offers strong parallels with Casa di Ricovero 236 *situla*: the body of the vessel is composed of two sheets in the upper part and a lower, smaller, sheet fixed with rivets. Then, the handles are so similar, always transverse with a circular section that, after an almost rectangular curve, end flat and elongated, fixed with two rivets to the body of the vessel. From the handles, often rings with dovetail pendants or stylised anthropomorphic figures are hanged.

The entire sample of “nachfolger der Eimer von Typ Hajdüböszörmény” could be consider quite close to Casa di Ricovero grave 236 *situla*, but an exemplar in specific, from Frög, Villach, represent the closest comparison⁹. In this regard, it should be noted that the Frög specimen slightly differs from other specimens of the type encoded by Prüssing for the highness of shoulder and, above all, the general, slender profile, more similar to the Este *situla*.

For the “nachfolger der Eimer von Typ Hajdüböszörmény” type, Prüssing provides a chronology between Ha C2 and the beginning of Ha D, second quarter of the 7th/beginning of the 6th century BC (Prüssing 1991: 54).

A typology of *situla* very close to the one just described is the **Sit 3** (Fig. 2, n. 3), represented in the examinated area by Villa Benvenuti 277 grave bronze vessel (Capuis & Chieco Bianchi 2006: 335, n. 1, tab. 188). This exemplar was employed as ossuary in a high-ranking female burial dated in literature to Este IIC-IIIa, at the end of the 8th/beginning of the 7th century BC (Capuis & Chieco Bianchi 2006: 337-339).

The body of the vessel is made up with two bronze sheets, fixed together with rivets; the lower part of the *situla* is formed by a smaller bronze sheet, that shapes also the bottom. Under the shoulder, two handles are attached to the *situla* with two pairs of rivets; the handles are made by a round bar with an almost rectangular curve and end in a flat, elongated *plaque*. A pair of omega pendants hang from them.

This type finds some punctual comparisons with a typology of *situlae* defined by M. Jereb (Jereb 2016: 22-31) “Eimer mit ungerippter Schulter”, *situlae* without handles, although the example from Villa Benvenuti shows a pair of fixed handles. The vessels analysed by Jereb are always made up with two or more sheets fixed together with rivets, a second lamina, shorter, is placed below, and then the bottom is made, generally, with a circular sheet fixed with small studs. The profile of these *situlae* is tronco-conical, the rim is folded and the shoulder is quite rounded. A punctual parallelism for Villa Benvenuti 277 *situla* come from 2789 grave of Most na Soči cemetery, in Tolmin, Slovenia (Jereb 2016: 23, n. 3 tab. 3).

The exemplars of the “Eimer mit ungerippter Schulter” type have a huge chronology between the Final Bronze Age-Urnenfeldern Culture and Ha C-D2 (Jereb 2016: 30-31).

⁷ In the Padova *situla* the decorated rows are two, while in the KelinKlein specimen are three.

⁸ Casa di Ricovero grave 236 houses also a female deposition, in a situliforme-shape ceramic vessel (Chieco Bianchi & Calzavara Capuis 1985: 310).

⁹ This parallelism is certainly to be consider punctual although the Villach exemplar shows a decoration on the body of the vessel, a secondary attribute compared to general morphology of the specimens.

Last *situla* with “fixed handles” to be discussed, called **Sit_4** (Fig. 2, n. 4) is the bronze vessel from “Tomba del Signore” in Castello di Rivoli Veronese (Bietti Sestieri 1976: n. 1, fig. 13). Rivoli Veronese cemetery, casually discovered in 1885 and then described by Stefano de Stefani in the same year in a publication in *Bullettino di Paleontologia Italiana* (de Stefani 1885: 1764-1780), had already been compromised in ancient times by different evidence, presumably from medieval to modern times. Some clusters of artefacts have come to light in a rather limited area – and recognised as possible destroyed graves –, including five bronze vessels – above all a *situla*, a small *cista* and a basin –, two fibulae, a sword with bronze handle and iron blade and an iron spearhead (de Stefani 1885: 1777). Although there is no reliable excavation data, a recent reinterpretation of the context by M. Cupitò has proposed that the *situla*, the *cista*, the basin, the fibulae, the sword and the spearhead could belong to a single high-ranking male burial (Cupitò 2017: 521-522).

Rivoli *situla* has a tronco-conical profile and a distinct neck; the upper part of the vessel consists of a bronze sheet fixed together with flattened rivets while the lower part is made of a shorter sheet. The rim of the *situla* is folded, the shoulder is rounded and on it, two cast handles with a rectangular curve profile and a twisted central section, are fixed. From the handles hang two rings with a pair of anthropomorphic pendants. The upper part of the *situla* is decorated in the Vogel-Sonnen-Barke style, the “sun-boat motif”, that shows the alternance of ornithomorphic protomes and embossed studs (von Merhart 1952: 38-58; Jockenhövel 1974: 16-54).

The specimen in analysis, for which there are some recent in-depth works in the literature (Bietti Sestieri 1976; Iaia 2005; Cupitò 2017), belongs to the category of *situlae* defined as Hajdüböszörmény, in specific, to the peripheral and more recent production of the type, which can be framed in a mature/advanced moment of the 8th century BC (Iaia 2005: 223-236; Cupitò 2017). A very precise comparison for the Rivoli *situla* has been identified in the *situla* from “Ternopil Oblast”, a sporadic vessel from the Ukrainian area that appeared on a Russian website for the first time in 2016, in association with a bronze helmet (Tarbay 2018). Although the finding is sporadic, the stylistic analysis of the artefact express by Tarbay in a dedicated article, places the specimen in the production of *situlae* subsequent to HaB horizon – final decades of the 8th century BC –, in the same chronological span given to the “Tomba del Signore” entire assemblage by M. Cupitò (Cupitò 2017: 523-526).

Situlae with movable handles

The only type here discussed with numerous exemplars is **Sit_5** (Fig. 3, nn. 1-4), the first type individuated with movable handles and composed of 4 specimens, as follows: *situlae* from Este Villa Benvenuti grave 278 (Capuis & Chieco Bianchi 2006: n., 51, tav. 196), Este Casa di Ricovero grave 234 (Chieco Bianchi & Calzavara Capuis 1985: n. 7, tav. 188), Este Casa di Ricovero grave 160 (Chieco Bianchi & Calzavara Capuis 1985: n. 2, tav. 72) and probably a fragment of the upper part of a bronze vessel from Montebelluna-Posmon grave 3 (Manessi & Nascimbene 2003: n. 2, fig. 40).

These *situlae* have a tronco-conical but sinuous profile, the body of the vessel is formed by one or two sheets fixed with rivets and another lower, smaller lamina – often with a particular rectangular profile – that shapes the bottom. A circular lamina could be fixed to the bottom with rivets or through an interlocking system. The rim is folded, the shoulder high and rounded.

These *situlae* could have two noose-shaped attachments for the movable handle, which is made with a circular rod with folded terminations, in an ornithomorph-shape head.

In Sit_5 type, *situlae* from Este Villa Benvenuti grave 278 and Este Casa di Ricovero grave 234 could be consider totally conform to the type, while the *situla* from Este Casa di Ricovero grave 160 can be seen as a variant of the type: this specimen, indeed, has a very sinuous profile, which becomes particularly slender towards the bottom. Furthermore, *situla* fragments from Montebelluna-Posmon grave 3 are considered as “comparable to the type”, due to the fragmentation of the vessel, so not completely readable.

The comparisons identified for the type come from the Hallstattian area and belong to the following types: the first one, for Slovenian Hallstattian area is the subvarieties of “Type 3”, 3A3 “mit angenieteter und mit Bronzeblechstreifen verstärkter Bodenschale”, i.e., “with riveted bottom reinforced with bronze strips” (Jereb 2016: 42) and, in specific, the best comparison coming from Novo Mesto, grave 335 of Kandija cemetery (Jereb 2016: 42, n. 43, tab. 43), for the general profile and, in addition, for the same fixing-system of the bottom.

The second comparative type coming from Slovenian area is the subvarieties of “Type 3”, 3A2 “Halslose Situlen mit angenieteter Bodenschale, gerundeter und gerippter Schulter, nach außen gebordeltem Mundungsrand und einem Henkel”, i.e. “without neck, rounded and fluted shoulder, extroverted rim and handle” (Jereb 2016: 40-41); from Most na Soči cemetery, Tolmin, grave 721 (Jereb 2016, n. 38), a *situla* with sinuous profile could be compared with Sit_5 variant of the type, from Villa Benvenuti grave 160.

For the Austrian area, the type “Halslose Situlen mit Omega-förmigen Attaschen”, i.e., “without neck with omega-shaped attachments” defined by Prüssing (Prüssing 1991: 59-60) could be consider in its entirety as a parallelism with Sit_5 type, in specific if it observes, for the general profile and the set of attributes, Hallstatt grave 307 *situla*, (Prüssing 1991: 60, n. 153, tab. 30) and KleinKein *situla* form the “Kroll-Schmiedkogel” (Prüssing 1991: 60, n. 154, tab. 30), even if this exemplar shows bigger attachments for the movable handle.

The chronology of the above-mentioned types is rather broad: the type of *situlae* formulated by Jereb is placed between phases IIa and IIb of St. Lucia in Tolmin – i.e., Ha D1-D2, during the 6th/beginning of the 5th century BC – (Jereb 2016: 73), while the *situlae* with omega-shaped attachments are attested for a long time, between phases Ha C and Ha D3, from the middle of the 7th/middle of the 5th century BC (Prüssing 1991: 69-70).

Exemplars examined for the Veneto region come from graves with a coherent chronology, between Este IIIB1 and Este IIIB2, i.e., between the middle of the 7th century BC and the first quarter of the 6th century BC.

Even if incomplete, a second bronze *situla* from Casa di Ricovero grave 236 (Chieco Bianchi & Calzavara Capuis 1985: 303, n. 18, tab. 205, only the upper part) represents the type **Sit_6** (Fig. 3, n. 5); this specimen is a fragmented sample of the upper part of a *situla* – wrongly consider together with the bottom of a bronze *cista* (see below “Cist_unicum_A”) in the 1985 publication of the context (Chieco Bianchi & Calzavara Capuis 1985) – with a tronco-conical body, folded rim and keeled shoulder. Set just below the rim there are two loop-shaped attachments in which two twisted rod handles, terminating in an ornithomorph-shape head, are inserted.

A good comparison for this exemplar come from San Vitale cemetery in Bologna, precisely from grave 759, a burial dated to Villanoviano III in Morigi Govi relative chronology. i.e., between the second half of the 8th-beginning of the 7th century BC. (Morigi Govi 1976: 171 at seq.).

San Vitale *situla* was published for the first time in 1959 by Hermann Müller Karpe as an almost fully intact specimen, marked by a well-developed neck and a folded rim. Indeed, in the 1975 edition of the grave by Pincelli & Morigi Govi (Pincelli & Morigi Govi 1976) – where the materials are published in photographs and without restoration – it is evident, at the contrary, that the bronze vessel is particularly fragmented and only the handle and a few fragments of the upper part of the body are preserved. The S. Vitale *situla* is characterised by the presence of just one movable handle insert in two loop-shaped attachments placed under the rim; observing the photographs published by Pincelli & Morigi Govi is even more clear that the attachments/handle system of San Vitale *situla* is the same that 236 Casa di Ricovero grave, with the only difference that the *situla* from Este has two handles.

Exclusively for the two twisted rod handles, a comparison is identified also in Hallstatt grave 574 *situla* (Prüssing 1991: n. 163).

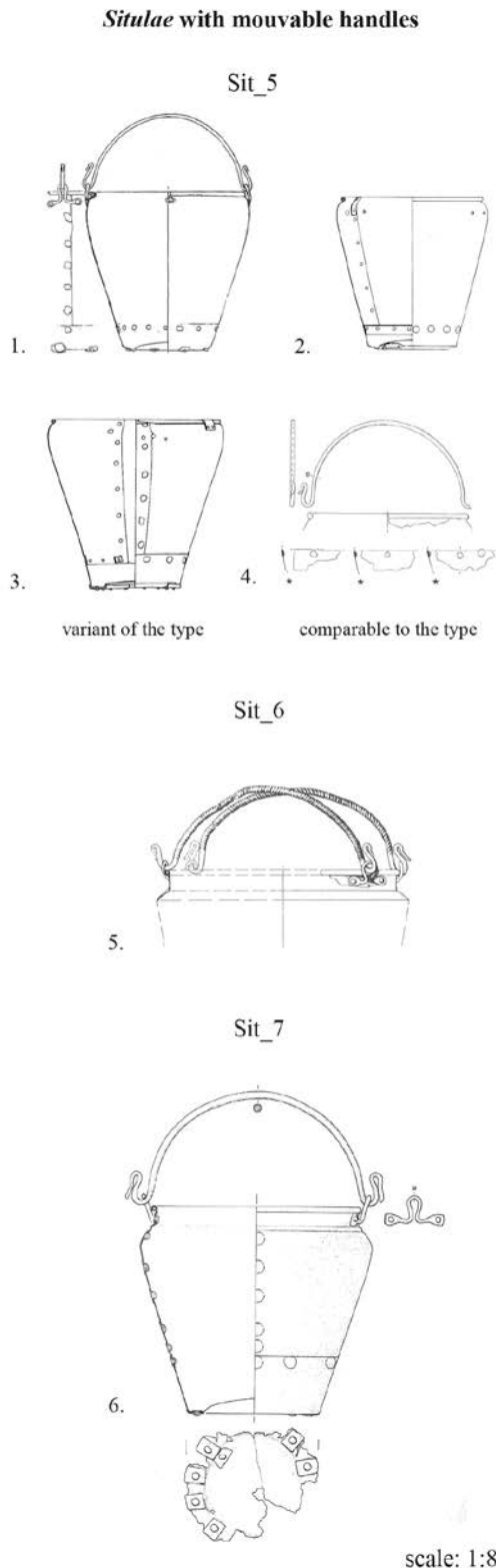

Fig. 3: Types of *situlae* with movable handles here identified: 1. Grave 278, Villa Benvenuti cemetery, Este (PD); 2. Grave 234, Casa di Ricovero cemetery, Este (PD); 3. Grave 160, Casa di Ricovero cemetery, Este (PD); 4. Grave 3, Posmon cemetery, Montebelluna (TV); 5. Grave 236, Casa di Ricovero cemetery, Este (PD); 6. Sporadic find, Borgo Santa Croce, Padova. / I tipi di *situle* a manici mobili identificati: 1. Tomba 278, cimitero di Villa Benvenuti, Este (PD); 2. Tomba 234, cimitero Casa di Ricovero, Este (PD); 3. Tomba 160, cimitero Casa di Ricovero, Este (PD); 4. Tomba 3, cimitero di Posmon, Montebelluna (TV); 5. Tomba 236, cimitero Casa di Ricovero, Este (PD); 6. Ritrovamento sporadico, Borgo Santa Croce, Padova.

Sit_7 (Fig. 3, n. 6), finally, is a small bronze *situla* published in 2004 by M. Cupitò as a sporadic find (Cupitò 2004: 105, n. 4, fig. 2), part of a batch of materials discovered in Borgo S. Croce district, on the southern periphery of Padova and now stored in the warehouses of the Civic Museum of Padova (Cupitò 2004: 103). According to the first report edited by L. Busato in 1888, the *situla* is part of a destroyed grave context.

This exemplar is characterised by a tronco-conical profile and a distinct neck, the body is made up of two bronze laminae fixed with large studs. The bottom consists of a third flat sheet blocked with studs and reinforcing bands. The rim is folded over a metal core, probably a bronze circular bar. The shoulder is slightly angled and sloping and present a single rib placed between the neck and the shoulder itself.

On the neck, two loop-shaped attachments for a round-rod movable handle with an ornithomorph-shape head termination are fixed with two small rivets.

This specimen, the smallest in the sample in exam – only 18 cm high – find some good comparisons in Austrian area, in two types defined by Prüssing in 1991. The first parallelism is represented by the “*Situlen mit Hals und parallelseitigen Attaschen*” (Prüssing 1991: 57-58, nn. 130-138) i.e., “*Situlae* with distinct neck and parallel side attachments” type; this category of *situlae* is characterised by a tronco-conical body and a distinct neck, the shoulder may be slightly angled or more rounded. The upper part of the vessels is formed by an overlapped sheet, fixed with large studs, to which, below, a sheet of smaller size is joined. The bottom often presents a slight concavity and sub-rectangular exterior margins. Two noose-shaped attachments are fixed on the neck, in which a round-rod movable handle with an ornithomorph-shape head termination is inserted.

The second type that shows several similarities with the *situla* of Borgo Santa Croce is the type defined “*Situlen mit Schulterrippen*”, (Prüssing 1991: 60-61, nn. 156-163) “*Situlae* with ribs on the shoulder”; as the name of the type itself, this category of *situlae* is characterised by the presence of one or more ribs placed between the neck and shoulder. The other principal attributes and the overall profile of these specimens are the same as those defining for the above-mentioned type “*Situlae* with distinct neck and parallel side attachments”.

According to Prüssing, these types of *situlae* belong to Hallstatt C and D phases, in specific “*Situlen mit Hals und parallelseitigen Attaschen*” have a late chronology (Ha D) while *Situlen mit Schulterrippen* comprehend exemplars dated to Ha D3 (Prüssing 1991: 68-70).

Situlae without handles

Sit_8 (Fig. 4, n. 1), is a bronze vessel from 234 grave of Casa di Ricovero cemetery in Este (Chieco Bianchi & Calzavara Capuis 1985: 285, n. 1, tab. 188). The upper part of the *situla* is made of two sheets joined together with rivets; a third sheet, which also serves as bottom, is joined to the upper part by rivets. Finally, the bottom has a convex shape, with a flat bronze lamina, fixed with nails, to strengthen the bottom. The general profile of the *situla* has a tronco-conical shape, the rim is folded, the neck is straight and developed, the shoulder is rounded and slightly sloping.

A precise comparison for this artefact, although larger in size, comes from the cemetery of Santa Lucia in Tolmin, grave 2789; the parallelism between these two specimens was already emphasised when the artefact was published in 1984 by G. Bravar (AA.VV. Caput Adriae 1984: 142-146). Since no associated grave goods have been published for the Friulian *situla*, it proposes for the type the chronology attributed to 234 Casa di Ricovero grave from Este, i.e., Chieco Bianchi & Calzavara Capuis 1985 IIB1-III B2 phase, last decades of the 7th century BC.

Without any punctual comparisons and therefore definable as “*unica*” are four exemplars of *situlae*, as follows:

Sit_unicum_A (Fig. 4, n. 2) come from Este, Fondo Rebato, grave 187 (Frey 1969: n. 12, tab. 11); this exemplar is a *situla* with a

tronco-conical body formed by a bronze sheet joined with rivets; the bottom is made by a short sheet fixed to the body with rivets. The rim is flat, the shoulder is wide and keeled, the bottom is convex. This *situla* has an embossed decoration formed by rows of small dots alternating with larger punches dots creating simple meanders; the last row of dots towards the bottom ends with a series of hanging “Ls”.

Este Fondo Rebato 187 grave is dated in literature to the last decades of the 7th century BC.

Sit_unicum_B (Fig. 4, n. 3), is a *situla* with distinct neck and a tronco-conical shaped body recover in Villa Benvenuti cemetery, grave 122 (Capuis & Chieco Bianchi 2006: 267, n. 1, tab. 141). The upper part of the vessel is formed by a bronze sheet joined with a series of rivets; the bottom, convex, is formed by a shorter sheet attached to the body with rivets. The rim is everted and slightly bent downwards, the neck is straight and the shoulder is rounded. This specimen is characterised by an embossed decoration covering the whole surface of the upper sheet: on the shoulder there is a meander motif, below which there are a series of small dots and a third band of studs impressed with concentric circles. A central register presents a decoration formed by a sort of irregularly outlined triangles filled with dots and five stylised figures with a sinuous profile. This particular decoration is followed by two other bands alternating dot motifs and studs with concentric circles.

Este Benvenuti 122 grave is dated to the last decades of the 7th century BC (Capuis & Chieco Bianchi 2006: 274-276).

Amphorae

Few details are known about the discovery in the small village of Colognola ai Colli (Verona) (Salzani 1983: 31-32; here Fig. 5, n. 1) of a group of bronze artifacts that can be traced back to a despoiled grave. The Rizzardi family, owner of a bronze vessel found many years before, remembers that this exemplar must have been associated with a bronze knife with a cannon handle, today untraceable.

This exemplar has a distinct neck, biconical profile and a distinct foot; this category of bronze vessels is also known as ‘*amphorae*’. The rim is folded, the neck straight and rather long, the shoulder is sloping and slightly angled. Just below the shoulder, two fixed handles are placed, blocked with two small rivets. Finally, the distinct foot has a tronco-conical profile, slightly flared.

In literature, and specifically in the volume dedicated to the toreutic production edited by Cristiano Iaia, the *amphora* from Colognola ai Colli is included in the *Gevelinghausen*-type neck vessels: the type (Iaia 2005: 163-170), which is divided into two Varieties according to size and typology of decoration, includes, in the Variety A – larger size and decoration in “Hajdüböszörmény” style (Jockenhövel 1974: 16-54) –, an example from grave AA1 at Veio-Quattro Fontanili.

Variety B, which includes the *amphora* from Colognola ai Colli and another vessel from “Tomba del Carrettino” in Como cemetery, is characterised by a small size and decorated with studs, dots, semi-circles and ornithomorphic motifs.

According to the dating of grave AA1 at Quattro Fontanili, Variety A seems to have been widespread from the beginning of the 8th century BC (Pacciarelli phase 2A2, Pacciarelli 2010: 267-273), whereas Variety B can be defined as an evolution of the type during the final decades of the 8th century/first half of the 7th century BC and also appears in later burials, such as the Como one, perhaps as *keimelion* (Iaia 2005: 169).

Cistae

The sample of *cistae* taken in exam consists of 4 specimens, three undamaged and one fragmented – just the bottom is preserved –.

Cistae with fixed handles

The first type recognised is Cist_1 (Fig. 5, n. 2), represented by Fondo Candeco grave 307 *cista* (Stjernquist 1967: n. 2, tab. IV), consisting of a bronze sheet joined with rivets and a bottom shaped as concentric circles, interlocked to the body; the sheet has 7 raised strings. The specimen has two non-movable handles made by a round bar with an almost rectangular shape, set under the second stringcourse and attached to the body with two little bronze sheets and three rivets, between them there is a concentric circles decoration. The type finds good comparisons, except for the number of stringcourses. The most precise parallelism is an exemplar from Magdaleska gora grave 29, especially for the characteristics of the handles and the bottom; this *cista* is identified by M. Jereb in the “Variety” 5B “Rippenzisten mit festen seitlichen handgrifen”, *cistae* (Jereb 2016: 85, n. 205) with stringcourses and lateral handles, dated to S. Lucia Ila-lib horizon, Ha D1-D3, entire 6th century

Situlae without handles

Sit_8

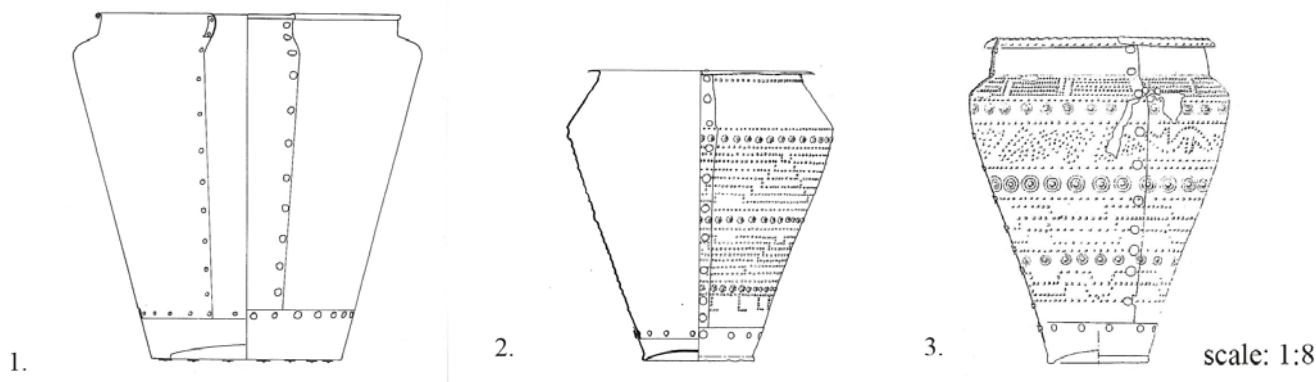

Fig. 4: Types of *situlae* without handles here identified: 1. Grave 234, Casa di Ricovero cemetery, Este (PD); 2. Grave 187, Fondo Rebato cemetery, Este (PD); 3. Grave 122, Villa Benvenuti cemetery, Este (PD). / I tipi di *situle* privi di manici identificati: 1. Tomba 234, cimitero Casa di Ricovero, Este (PD); 2. Tomba 187, cimitero di Fondo Rebato, Este (PD); 3. Tomba 122, cimitero di Villa Benvenuti, Este (PD).

BC-first half of the 5th century BC (Jereb 2016: 90-91), a type already codified by Bertha Stjernquist in 1967 – group I, Este grab 9 – and dated between Ha C2 and Ha D1, from the middle of the 7th-second half of the 6th century BC (Stjernquist 1967: 98-103). Another parallelism came from the Certosa cemetery in Bologna, precisely from grave 357 (Stjernquist 1967: n. 1, tab. I), dated at Certosa phase (Ha D2-3).

Fondo Candeco grave is traditionally dated to Este III B2 phase, i.e., last decade of the 7th-first quarter of the 6th century BC.

Cistae with movable handles

Cist_2 (Fig. 5, n. 3) is a type of *cista* characterised by a jointed sheet with rivets and a shaped bottom, fixed by interlocking system; on the bronze sheet there are four raised strings. The two loop-shaped attachments are fixed under the rim with two rivets, and a twisted bar handle with folded end is inserted in them; a decoration with a series of embossed studs is visible under the last string.

In the sample in exam, this type includes the *cista* from Villa Benvenuti grave 277 (Capuis & Chieco Bianchi 2006: 335, n.7, tab. 188). Based on the morphology of handles and the particular decoration, the best parallelism came from Nesazio, Istria, grave 5 (Stjernquist 1967, n. 1, tab. 52). Nesazio *cista* differs from Villa Benvenuti one just for a thin string placed between the four, larger, strings.

Other good comparisons, very similar to Benvenuti 277 *cista* for the general shape, the conformation of the bottom and for the loop-shaped attachments came from Picugi, Istria (Stjernquist 1967: n. 6, tab. XX) and from Ober-Ulm, Mainz (Stjernquist 1967: n. 1, tab. XXI), both sporadic from the cemeteries.

All these specimens appear in “*Rippenzisten mit beweglichen henkeln*”, “*Stringed cistae with movable handles*” type, codified by B. Stjernquist in 1967 – group II, Este –, with a long-term chronology, between Ha C1 and Ha D2 – entire 7th and 6th century BC –, depending to geographic and cultural area (Stjernquist 1967: 103-108).

Villa Benvenuti 277 grave is attributed to the transition horizon Este IIC-III A – end of the 8th-beginning of the 7th century BC – (Capuis & Chieco Bianchi 2006: 333-339) and the *cista* in specific, is considered characteristic of the Este IIC phase in the chronological overview elaborated by R. Peroni (Peroni et al. 1975: 69, 73 and 114, figg. 13, 1 and 29).

Last type of *cistae* identified, **Cist_3** (Fig. 5, n. 4), is represented by Rivoli Veronese “*Tomba del Signore*” *cista* (de Stefani 1885: n. 3, tab. XXIV), consists of a sheet joined with rivets and a bottom secured with interlocking system; the bronze sheet has four raised strings. Immediately below the rim there are two loop-shaped attachments into which two rod handles with folded ends are inserted¹⁰. This specimen has been already object of an in-depth analysis by M. Cupitò in 2017, where a punctual comparison is identified in the *cista* from Manching, Bayern (Stjernquist 1967: n. 3, tab. 21), that appear in “*Rippenzisten mit beweglichen henkeln*”, “*Stringed cistae with movable handles*” type, codified by B. Stjernquist in 1967 – group II – and by C. Jacob in 1995 (Jacob 1995: 117, n. 387, tab. 72). The circumstances of discovery of the Manching *cista* appear, however problematic, as the specimen was found during the construction of a well in the *oppidum* area, together with materials dated to La Tène phase. Jacob stylistically approximates this *cista* to specimens from the more recent Hallstatt phase (Jacob 1995: 117-118).

Due to its fragmentary character, *cista* from Casa di Ricovero, grave 236, can not be compared with any type identified, so this exemplar is considered as **Cist_unicum_A** (Fig. 5, n. 5). Of this *cista* is only preserved the bottom, shaped and convex in the central part, attached to the body by interlocking system and a small part of the bronze sheet, characterised by two large strings. B. Stjernquist consider this exemplar in “group II” in her typology (Stjernquist

1967: 103-108). In the original publication this specimen is wrongly considered as the bottom of a *situla* here discuss as Sit_6. (Chieco Bianchi & Calzavara Capuis 1985: 303).

Cups

Six specimens in analysis could be placed in the family of the cups; for these, a type with three Varieties is defined, as follows.

Based on the long established “*Beckentassen*” typology (von Merhart 1952: 15 et seq.; Jacob 1995: 41-42), the examples in analysis could be generally included in this macro-type, but more in detail, it can be recognised here three *Variants*: without decoration (a), with meanders and triangles engraved decoration (b) and with lines and triangles engraved decoration (c) for which some punctual comparisons have been identified.

The first *Variant*, **Cup_1_a** (Fig. 6, n. 1), is represented by Fondo Randi, grave 14 non decorated cup (Frey 1969: n. 17, tab. 2); this example has a slightly flattened calotte profile with a slightly umbilicate bottom; the handle is a raised band that extends from the rim and is attached to the bowl with four conical rivets, two at the rim and two on the body. For this cup a quite similar parallelism could be find in a specimen from Hallstatt, sporadic from the cemetery (Prüssing 1991: 33, n. 30 tab. 6), that differs from Randi 14 in the shape of the rivets, in this case not conical but flat.

Randi 14 grave, coming from southern cemetery of Este, is dated in literature to the middle of the 8th century BC.

The second *Variant*, **Cup_1_b** (Fig. 6, n. 2), include the first cup of Padova Via Tiepolo-San Massimo “*Tomba dei Vasi Borchiatii*” (Gamba et al. 2011: 79, n. 5, tab. 3), characterised by a slightly flattened calotte-shape body and a slightly umbilicate bottom; a raised handle with side ribbing, considerably folded towards the inside of the cup, departs from the rim and attaches to the bowl – through a tripartite plaquette – with five flat rivets, two at the rim, three on the body of the cup. Under the small offset rim runs a decoration with engraved geometric motifs composed of meander and reversed triangles.

Globally, the best comparisons identified came from Salzburg-Maxglan cemetery, grave 400 (Schäfer 2019: Fig. 4) and Albate cemetery (Como) grave 12 (de Marinis 2016: n. 6, fig. 18).

The Salzburg-Maxglan cup shows the same profile, handle and bottom conformation and above all, a very similar decoration of “*tomba dei Vasi Borchiatii capeduncola*”. These two specimens differ in the shape of the rivets that fix the handle to the body of the cup, in the case of “*tomba dei Vasi Borchiatii*” they are flat, in Salzburg exemplar, conical; the Salzburg cup has also a geometric decoration on the handle. This context represents one of the most ancient graves in the entire Maxglan cemetery, dated to very beginning of Ha C, last decades of the 8th century BC (Schäfer 2019: 203).

Albate grave 12 cup is a parallelism extremely close to Cup_1_b: the general profile, slightly flattened, of the two exemplars is very similar, the decoration is characterised by the same pattern – but in the Albate cup the reversed triangles are more developed – and finally, the structure of the handle, raised, tripartite with side ribbing, well corresponds. Albate grave is dated by R.C. de Marinis to Golasecca IIA-B, in the middle of the 6th century BC. (de Marinis 2016: 28; 43).

Other parallelisms are also identified for some specific attributes: for the general profile, the “*Tomba dei Vasi Borchiatii*” cup can be compared with an exemplar from Uttendorf im Pinzgau (Salzburg), grave 4 (Prüssing 1991: 33, n. 25, tab. 4), while for the decoration with meander and triangles finds a good comparison with a cup from Hallein (Salzburg), grave 68/2 (Prüssing 1991: 33, n. 26, tab. 4). Finally, the handle trend is very similar to that of the Hallstatt grave 506 cup (Prüssing 1991: 32, n. 22, tab. 3).

¹⁰ Rivoli *cista* represented in de Stefani 1885 publication presents two rod handles: this detail, based on the later studies, is an improper nineteenth-century arbitrary integration.

Amphorae



Cistae with fixed handles

Cist_1

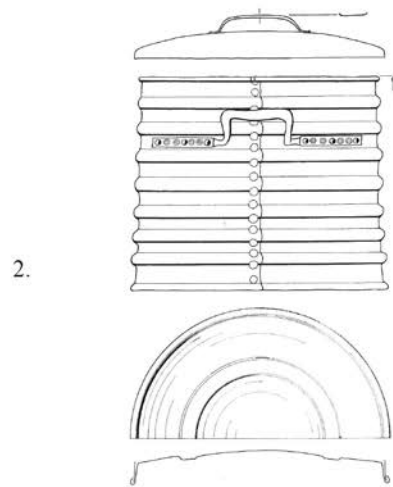

Cistae with movable handles

Cist_2

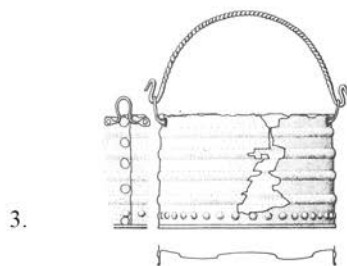

Cist_3



Cistae: Unicum



scale: 1:8

Fig. 5: Types of amphorae and cistae here identified: 1. Sporadic find, Colognola ai Colli (VR); 2. Grave 307, Fondo Candeco cemetery, Este (PD); 3. Grave 277, Villa Benvenuti cemetery, Este (PD); 4. "Tomba del Signore", Rivoli Veronese (VR); 5. Grave 236, Casa di Ricovero cemetery, Este (PD). / I tipi di anfore e ciste identificati: 1. Ritrovamento sporadico, Colognola ai Colli (VR); 2. Tomba 307, cimitero di Fondo Candeco, Este (PD); 3. Toma 277, cimitero di Villa Benvenuti, Este (PD); 4. "Tomba del Signore", Rivoli Veronese (VR); 5. Tomba 236, cimitero Casa di Ricovero, Este (PD).

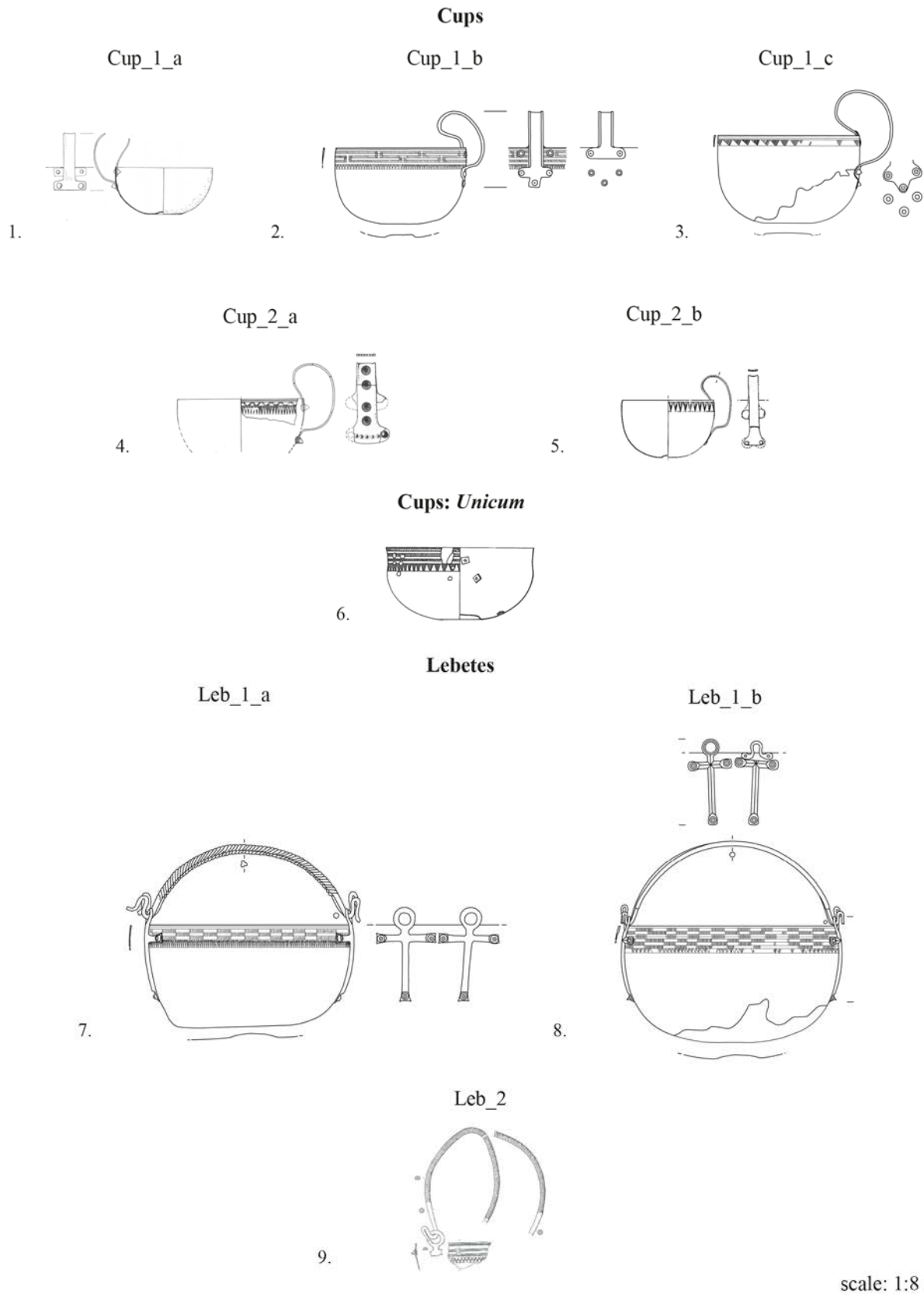

Fig. 6: Types of cups and lebetes here identified: 1. Grave 14, Fondo Randi cemetery, Este (PD); 2-3. "Tomba dei Vasi Borchiatì", Via Tiepolo-San Massimo cemetery, Padua; 4. Grave 236, Casa di Ricovero cemetery, Este (PD); 5. Grave 235, Casa di Ricovero cemetery, Este (PD); 6. Grave 160, Casa di Ricovero cemetery, Este (PD); 7-8. "Tomba dei Vasi Borchiatì", Via Tiepolo-San Massimo cemetery, Padova; 9. Grave 3, Posmon cemetery, Montebelluna (TV). // I tipi di tazze e lebeti identificati: 1. Tomba 14, cimitero di Fondo Randi, Este (PD); 2-3. "Tomba dei Vasi Borchiatì", cimitero di Via Tiepolo-San Massimo cemetery, Padova; 4. Tomba 236, cimitero Casa di Ricovero, Este (PD); 5. Tomba 235, cimitero Casa di Ricovero, Este (PD); 6. Tomba 160, cimitero Casa di Ricovero, Este (PD); 7-8. "Tomba dei Vasi Borchiatì", cimitero di Via Tiepolo-San Massimo, Padova; 9. Tomba 3, cimitero di Posmon, Montebelluna (TV).

All these north-alpine comparisons are included in the category of *capedunculae* defined as “*Beckentassen*”, formalized by Prüssing for the Austrian area and dated to the recent phase of Hallstattzeit, Ha D1, (Prüssing 1991: 34-35).

Cup_1_c (Fig. 6, n. 3) corresponds to the second cup of Padova Via Tiepolo-San Massimo “tomba dei Vasi Borchianti” (Gamba et al. 2011: 81; 84, n. 24, tab. 5); this cup, with slightly flattened calotte-shape body and slightly umbilicate bottom, presents the same raised handle with a tripartite attachment system and the small offset rim as Cup_1_b, but differs in the decoration, that consists in an engraved geometric motif composed of lines and reversed triangles and in the typology of the handles’ rivets, here conical.

Cup_1_c finds a quite good comparison, for the general profile and for the conical handles’ rivets, in the *capeduncola* of grave 8 of Albate cemetery (Como) (de Marinis 2016: n. 1, fig. 8), dated, based on the materials present in the burial, by R.C. de Marinis to G IIA or G IIA-B, during the 6th century BC (de Marinis 2016: 28).

More general comparisons – specifically for the handle: Etting, Bayern, tumulus 2 (Jacob 1995: 40, n. 50, tab. 9) and the decorative motif: Hostemice, Boem, sporadic from the cemetery (Siegfried-Weiss 1991: 60, n. 33, tab. 6) – come from the North Alpine area and belong to the type defined by Jacob’s “*Bronzetassen mit hochgezogenem Henkel*”, i.e., “*Bronze cups with raised handles*” (Jacob 1995: 39-42), a *longue durée* category with some exemplars dated to the ancient Hallstatt (Ha C) but widespread in more recent phases (Ha D1).

Cup_2 type (Fig. 6, nn. 4-5), which is very similar to Cup_1, differs from the latter mainly in the shape of the cup body and in the conformation of the attachment plaquette of the handle: Cup_2 shows clearly a globular calotte-shape profile and the attachment of the handle is a bipartite plaquette with two fixing rivets. Also in this case, two *Varieties* could be recognised.

Cup_2_a (Fig. 6, n. 4), from Casa di Ricovero grave 236 (Chieco Bianchi & Calzavara Capuis 1985: 303, n. 13, tab. 206), is a globular calotte-shape cup, missing the bottom. A raised band handle with lateral ribbings departing from the rim, decorated with incised “*dice eyes*” along the band and embossed studs on the end of the bipartite attachment. The handle is fixed to the vessel with four conical rivets, two at the rim and two on the body.

The decoration of the cup consists of a few incised lines under the rim, below which there is a first zig-zag band and a second band composed by long reversed triangles. For this exemplar, no punctual comparisons have been found.

Cup_2_b (Fig. 6, n. 5), from Casa di Ricovero grave 235 (Chieco Bianchi & Calzavara Capuis 1985: 298, n. 47, tab. 199), is a globular calotte-shape cup with umbilicate bottom; the raised band handle departing from the rim and end on the body of the vessel. The handle is fixed to the body of the cup with four flat rivets, two at the rim and two on the body, in a small, bipartite attachment. This exemplar is decorated, under the rim, with a series of long reversed triangles framed in two thin engraved lines. Again, for this cup, no parallelisms have been recognised.

Last cup examines, Casa di Ricovero grave 160 (Chieco Bianchi & Calzavara Capuis 1985: 127, n. 2, tab. 72) bronze cup, is considered, because of the lack of comparisons, as a *unicum*, **Cup_Unicum_A** (Fig. 6, n. 6). This cup has a flattened calotte profile with a slightly flared rim and an umbilicate bottom. The cup is decorated, below the rim, with three horizontal incised bands with short vertical lines on the inside; under this motif, a series of reversed triangles are enclosed between two incised lines. Some holes in correspondence to the rim and in the body of the vessel, testify to the presence, *ab origine*, of a raised handle.

Lebetes

For this category three exemplars, one fragmented and two complete, have been analysed; it is possible to establish two different types, the first one with two *Varieties*. However, bronze *lebetes* with cruciform attachments and twisted rod handle terminating in an ornithomorph-shape head represent a widely documented type over a long time widespread in Central and Eastern Europe, with a huge variety of morphological attributes or decoration pattern. The first classification of these exemplars is due to G. von Merhart in 1952 (von Merhart 1952: 6-14; 284-297) in which specimens are divided according to the overall shape of the basin and the morphology of the attachment, taking into account, where possible, the decoration pattern. The distribution and the circulation of *lebetes* with cruciform attachments has also been widely reviewed in literature in more recent years (Egg 1985; Marzatico 1998), emphasizing the wide *lebetes* in Europe.

Padova exemplars are generally attribute to “*Typ C*” codified by G. von Merhart (von Merhart 1952: Tab. 6; after: Egg 1985: 377; Marzatico 1998: 21-24; Gamba et al. 2011: 76-77), but, to date, no punctual comparisons have been found for any of these specimens.

Type defines **Leb_1** (Fig. 6, nn. 7-9) is characterised by bronze vessels with slightly flattened or hemispherical profile, two cruciform attachments in which a rod handle with an ornithomorph termination is insert; an incise decoration under the rim.

This type could be divided in two *Varieties*, based on the conformation of the cruciform attachments and handles.

Leb_1_a (Fig. 6, n. 7), from “Tomba dei Vasi Borchianti” grave (Gamba et al. 2011: 81, n. 22, tab. 5), is a *lebetes* with hemispherical profile and slightly umbilicate bottom; two cruciform attachments with flattened section are fixed just below the rim, and inside these a twisted rod handle with folded ends is inserted; the attachments are fixed to the body with conical rivets. This *lebetes* is decorated with engravings motifs under the rim, consist in a chess band and a series of reversed triangles, place between two engraved lines.

Leb_1_b (Fig. 6, n. 8), again from “Tomba dei Vasi Borchianti” grave (Gamba et al. 2011: 84, n. 25, tab. 6), present a very deep hemispherical profile with a large basin; the cruciform attachments have a triangular cross-section, one has a ring-shaped apex, the other, restored in ancient, ends in a loop-shape element. Two rod handles with folded ends fit into the attachments; the attachments are fixed to the bowl with conical rivets.

The decoration consists in an incised motif, placed under the rim, with a chess motif and a series of reversed triangles including in two engraved lines.

Thanks to the parallelisms identified, it could be identified a second type of *lebetes*, **Leb_2** (Fig. 6, n. 9), with only one occurrence from Montebelluna-Posmon cemetery, grave 3, dated to the end of the 7th -beginning of the 6th century BC (Manessi & Nascimbene 2005: 157, n. 3, tab. 41); of this exemplar, a fragment of the upper part of a *lebetes* with a hemispherical profile, is preserved, together with the remains of the cruciform attachments with a ring-shaped apex, in which a twisted rod handle with a folded end is inserted. Is also preserved a fragment of the rim, with an incised decoration composed by three bands of thick vertical incisions and a zig-zag decorated band.

This specimen finds some generic comparisons in the category of bronze vessels formulated by C. Jacob “*Bronzebecken mit Kreuztassen und Rundboden*”, i.e., “*Bronze basins with cross-shaped attachments and rounded rim*” (Jacob 1995: 84-86), widely distributed in contexts dated to the Ha D. A relatively good comparison came from Aislingen cemetery (Bayern), sporadic from the necropolis (Jacob 1995: 85, n. 230, tab. 35).

Basins

The only example of a continuous-profile basin found in the Veneto area is the specimen from the “Tomba del Signore” of Rivoli Veronese (Cupitò 2017: 515, n. 2, fig. 2), here define as **Bas_unicum_A** (Fig. 7, n. 1).

This basin has a low tronco-conical body, a twisted rim and a shaped bottom with a short foot. The decoration consists of embossed motifs of small dots, between which runs a studs’ row and a festoon motif with large studs impressed between the arches.

As already stated in Cupitò 2017, the exemplar under examination is not comparable in terms of its overall profile with none other specimen; on the other hand, the decoration with festoons and embossed studs refers to iconographies widespread in central Europe – specifically to the Hostomice type cups, also present in Italy between the end of the 9th and the beginning of the 8th century BC. There is a specimen of probable Etruscan origin preserved in the Römisch-Germanisches Zentralmuseum in Mainz – and in southern Etruscan area; in particular, strong affinities are recorded with the decoration of the helmet of the so-called “Well with a Bell Helmet” in Tarquinia-Arcatelle, dated at the beginning of the 9th century BC, although the common literature suggests for the helmet a chronology between the end of the Bronze Age and the first Iron Age.

The decoration with large studs surrounded by dots recalls Halstattian productions from the mature phases of the 8th/beginning of the 7th century BC.

Finally, Cupitò underlines the affinity between the twisted rim of the Rivoli basin and the vessel from Gevelinghausen, Westphalia (Cupitò 2017: 514-516).

The second basin specimen from the area in investigation is also classified as a *unicum*, **Bas_unicum_B** (Fig. 7, n. 2). This exemplar, used as lid for the *situla* above discuss “Sit_Unicum_B” from Casa di Ricovero grave 234 (Chieco Bianchi & Calzavara Capuis 1985: 285, n. 2, tab. 188), has a globular and large body and a wide flared neck; the bottom is slightly umbilicate. Near the rim there is a hole where a handle was probably set. As mentioned, the specimen has no comparison with known Early Iron Age contexts, either in Italy or in Europe in general.

High foot goblets

Among the bronze vessels found in Veneto region, it should be mentioned a goblet on a high foot, **Gob_unicum_A** (Fig. 7, n. 3), found in Este (PD), Casa di Ricovero grave 236 (Chieco Bianchi & Calzavara Capuis 1985: 307, n. 65, tab. 209). This particular specimen has a small bowl with a globular body, supported by three twisted and sinuous rods that create the supporting stem; the foot has a calotte profile where the twisted rods are fixed with studs. This exemplar represents a *unicum* in the area in exam and no parallelism have been found.

Simpula - Ladles

A category of bronze artefacts linked to feasting and drinking in aristocratic entourage and, specifically, used for filtering alcoholic beverages is that of ladles, known in literature as *simpula*.

The occurrences of this category in the Veneto are mainly attested from the end of the 8th century BC, and then continue and

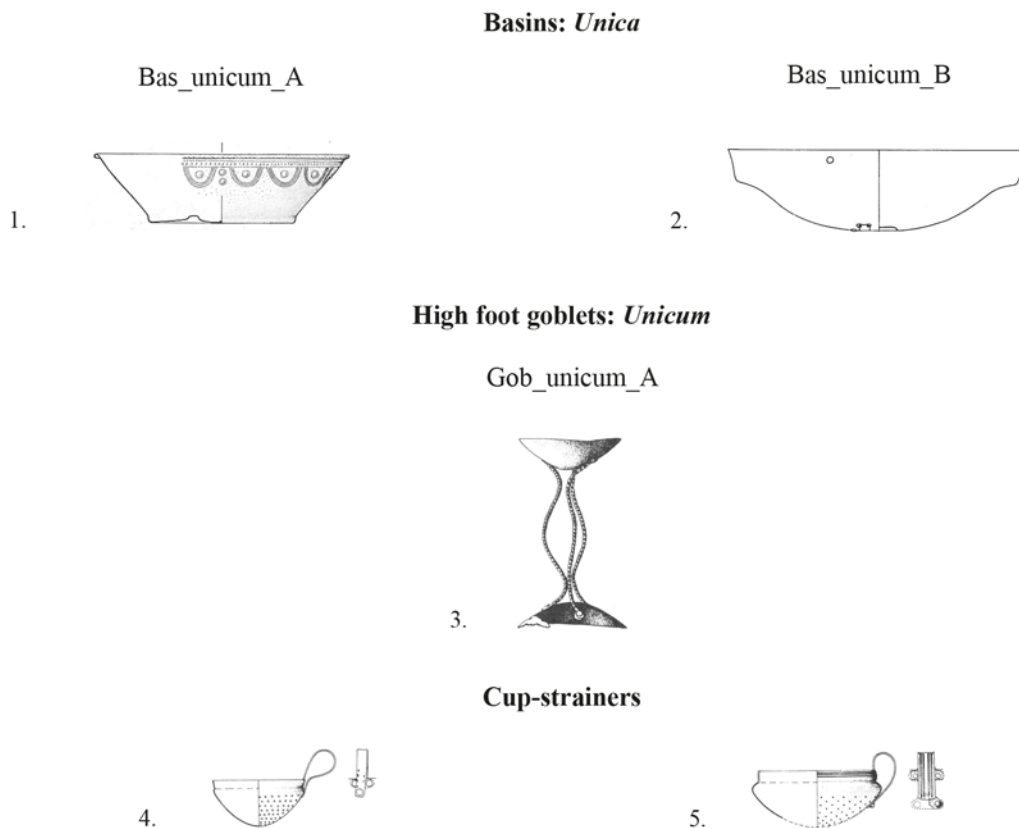

scale: 1:8

Fig. 7: Types of basins, high foot goblet and cup-strainers here identified: 1. “Tomba del Signore”, Rivoli Veronese (VR); 2. Grave 234, Casa di Ricovero cemetery, Este (PD); 3-4-5. Grave 236, Casa di Ricovero cemetery, Este (PD). / I tipi di bacilli, coppe su alto piede e tazze colino identificati: 1. “Tomba del Signore”, Rivoli Veronese (VR); 2. Tomba 234, cimitero Casa di Ricovero, Este (PD); 3-4-5. Tomba 236, cimitero Casa di Ricovero, Este (PD).

become numerically more consistent during the 7th century BC. The *simpula* here analysed come from some graves in the cemeteries of Este and Padova and, given their internal variability, a more generic classification is proposed, based on the type of fixing system and the shape of the handle.

The first type of *simpula*, **Simp_1** (Fig. 8, nn. 1-2), in which appear extremely fragmentary specimens, presents a handle formed by a folded rod, with a “dovetailed” attachment, fixed with rivets to the perforated basin. The handle can be made of plain or twisted rod. This type includes two specimens coming from the “Tomba dei Vasi Borchiatì” in Via Tiepolo-San Massimo cemetery (Gamba et al. 2011: 87, n. 92, tab. 8; here Fig. 8, n.1) and grave 318 from Palazzo Emo Capodilista-Tabacchi cemetery (de Min et al. 2005: 156, n. 22, fig. 185; here Fig. 8, n. 2), dated, respectively, to the end of the 8th century BC and to the second half of the 7th century BC.

Of the first *simpulum* of this type, only part of the handle made of a smooth rod and part of the punched basin are preserved; the specimen does not present any precise comparison. On the contrary, some parallels can be identified for the second specimen – even if generic – of which only a fragment of the twisted rod handle and its attachment is preserved. The first comparison identified, for the twisted rod handle, comes from the cemetery of Novo Mesto, tumulus 3, tomb 22 (Jereb 2016: 99-100, n. 251, tab. 119) which is assigned to the Stična I phase, i.e., early Ha C, first half of the 7th century BC. The second comparison, again exclusively due to the shape of the handle, comes from the Pommelkogel from Kleinklein (Prüssing 1991: 41, n. 78, tab. 9), as already pointed out dated Ha C2, second half of the 7th century BC.

The second type of *simpula* identified, **Simp_2** (Fig. 8, nn. 3-7), shows a flattened rod handle, fixed with one or two rivets to the perforated bowl. The handle can be undecorated or decorated with studded motifs executed with a punch or with embossed dots. The specimens of this type all come from burials in the cemeteries of Este: from Casa di Ricovero graves 155 (Chieco Bianchi & Calzavara Capuis 1985: 122, nn. 25-26, tab. 62; here Fig. 8, nn. 3-4) and 235 (Chieco Bianchi & Calzavara Capuis 1985: 295 n. 16, tab. 198; here Fig. 8, n. 5); from Villa Benvenuti, graves 89 (Capuis & Chieco Bianchi 2006: 157, n. 12, tab. 73; here Fig. 8, n. 6) and 278 (Capuis & Chieco Bianchi 2006: 342, n. 3, tab. 192; here Fig. 8, n. 7). The chronology of these burials is between Este IIIA and IIIB2, i.e., during the 7th century BC.

The specimens of this type with a handle decorated with a row of embossed dots along the margins could be compared with a *simpulum* from grave 13 of Tumulus 2 in Magdaleska Gora, Preloge (Jereb 2016: 100, n. 252, tab. 119), which, however, has a different attachment of the handle to the perforated basin. Magdaleska Gora grave is dated to the Ha C2 horizon.

The *simpulum* from “Tomba dei Vasi Borchiatì” in Via Tiepolo-San Massimo cemetery (Gamba et al. 2011: 87, n. 46, tab. 8), dated to the second half of the 7th century BC, is considered to be a *unicum*, **Simp_unicum_A** (Fig. 8, n. 8), characterised by a handle made of a smooth flattened rod and a dovetail fixing system, with two rivets on the perforated basin.

A particular type of *simpulum*, for which no comparisons have been found, comes from grave 236 of Casa di Ricovero cemetery in Este (Chieco Bianchi & Calzavara Capuis 1985: 303, n. 17, tab. 206). This specimen, **Simp_unicum_B** (Fig. 8, n. 9), shows a large punched basin and a decidedly short band-handle with a dovetailed termination; the handle presents a distinctive three-ribbed decoration and a circular applique. This occurrence represents the oldest attestation of this category based on the chronology of Casa di Ricovero 236 grave *assemblage*, dated to the middle of the 8th century BC.

Discussion

Types here defined generally consist, as illustrated, of a single occurrence, for which a few comparisons in contemporary contexts,

mostly in the Austrian and Slovenian Hallstattian area, are identified. Thanks to these parallelisms, it was therefore possible, in many cases, to insert the analysed artefacts into already established and codified typologies, both extra-Veneto region and extra-Italic, underlining the well-known wide-ranging circulation of bronze-sheet materials. Otherwise, some types of artefacts found in Veneto region appear to have slightly older chronology than the transalpine productions.

The well-known *situla* used as container for the ossuary of “Tomba dei Vasi Borchiatì” in Padova, here type Sit_1, is part of the widely codified Kurd type, widely spread at the end of the Bronze Age and which includes among its oldest examples, artefacts widespread in the Transdanubian area, Croatia, Slovenia, Bosnia, Slovakia but also in Switzerland, Austria, Germany and, above all, Italy. A recent review of some key-contexts has involved the hoards where Kurd *situlae* seem to make their appearance for the first time: these are, in specific, the Kurd-hoard (Hungary) and the Mezzocorona (Trento) and Merlara (Padova) hoards. The study of these contexts has established that the Mezzocorona and Merlara hoard could be definitely date to the Bz D, Peschiera horizon, while the Kurd-hoard should be attributed to the Ha A1 or at the beginning of A2, probably most precisely to the A2 phase – in particular observing the comparisons identified with Várvolgy-Szebike-tető assemblage – (Jankovits 2017: 456). On the basis of these recent data, it could be assumed an early codification of the Kurd-*situla* type in the northern Italian area during the Recent Bronze Age, with a subsequent spread to the Balkan and Hungarian areas during the Final Bronze Age. (Jankovits 1996: 306-308; Marzatico 1998: 18; Jankovits 2017: 448).

An elaboration of the type during the Iron Age, attested around the middle of the 8th century BC, is recognisable in the Italic area in *situlae* from the cemeteries of Bologna, Veio and Verucchio. During the 7th century BC, the type is also attested in Trentino, in Golasecca contexts and throughout the Etruscan area, as far as Pontecagnano (Gamba et al. 2011: 74). Even in the northern and eastern Alpine panorama, the spread throughout the 7th century BC of Kurd *situlae* generally characterised by local reworkings is clear (Dehn et al. 2005: 151-155).

As already suggested by Gamba and Gambacurta, the Padova specimen, which can be dated to the last decades of the 8th /beginning of the 7th century BC based on the associated grave goods, seems to belong to a slightly later phase than the oldest Villanovan specimens. This *situla* would therefore place between the Villanovan attestation and the later occurrences identified both in the north Alpine and eastern Alpine area – as evidenced by the comparisons found in the necropolis of Magdaleska gora and in the Pommelkogel of Kleinklein – and in the Golasecca area, generally dated to the middle/end of the 7th century BC.

Interesting parallels, both typologically and, above all, culturally and chronologically, have been identified between the *situla* from Rivoli (Sit_4) and the Ukrainian specimen – of which, however, neither the context nor the circumstances of its discovery are known – from Termopil Oblast (Tarbay 2018): the two *situlae*, both belonging to a mature and peripheral production of the Hajdüböszörmény type, are perfectly comparable, both in terms of the overall morphology of the vessel and its decorative motifs. The in-depth analysis proposed by Tarbay in allows to place the Ukrainian specimen in the Hajdüböszörmény *situlae* production of the final phase of the 8th century BC, a chronological range perfectly in agreement with the dating that Cupitò proposed for the entire assemblage of the “Tomba del Signore” of Rivoli (Cupitò 2017: 521-522). This additional comparative data further emphasises, if need be, the wide circulation and very high intrinsic value of this production of *situlae* and at the same time underlines the particularly high status of the man buried in the Rivoli grave, who own high-value items largely relating to the cultural sphere of Central and Eastern Europe (Cupitò 2017: 525).

On the sporadic *situla* from Padova, Borgo Santa Croce (Sit_7) the identified parallels from the Austrian Hallstattian area may sug-

Simpula-Ladles

Simp_1



Simp_2

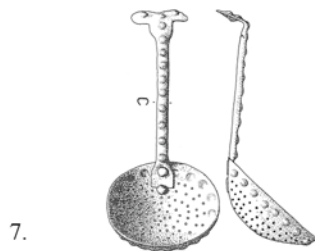
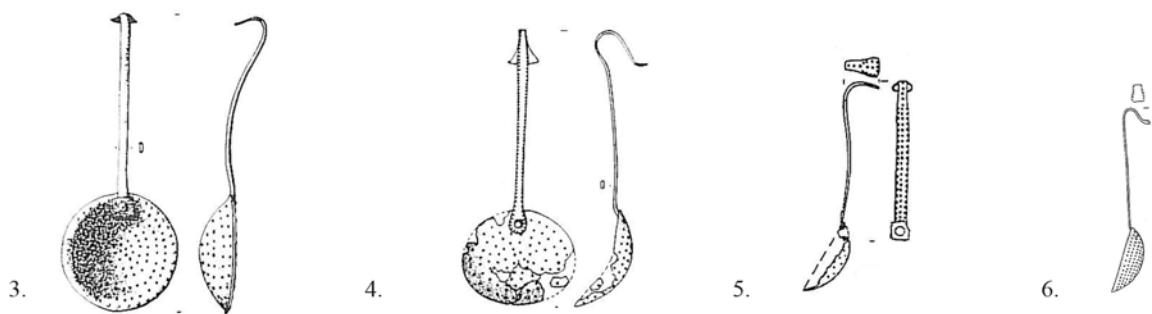

Variant of the type

Simpula-Ladles: Unica

Simp_unicum_A

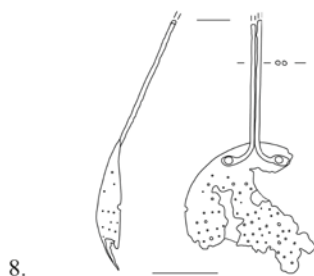

Simp_unicum_B

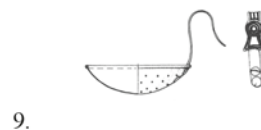

scale: 1:4

Fig. 8: Types of simpula-ladles here identified: 1. "Tomba dei Vasi Borchiatì", Via Tiepolo-San Massimo cemetery, Padova; 2. Grave 318, Palazzo Emo Capodilista-Tabacchi cemetery, Padova; 3-4. Grave 155, Casa di Ricovero cemetery, Este (PD); 5. Grave 235, Casa di Ricovero cemetery, Este (PD); 6. Grave 89, Villa Benvenuti cemetery, Este (PD); 7. Grave 278, Villa Benvenuti cemetery, Este (PD); 8. "Tomba dei Vasi Borchiatì", Via Tiepolo-San Massimo cemetery, Padua. / I tipi di simpula-mestoli identificati: 1. "Tomba dei Vasi Borchiatì", cimitero di Via Tiepolo-San Massimo, Padova; 2. Tomba 318, cimitero di Palazzo Emo Capodilista-Tabacchi, Padova; 3-4. Tomba 155, cimitero Casa di Ricovero, Este (PD); 5. Tomba 235, cimitero Casa di Ricovero, Este (PD); 6. Tomba 89, cimitero di Villa Benvenuti, Este (PD); 7. Tomba 278, cimitero di Villa Benvenuti, Este (PD); 8. "Tomba dei Vasi Borchiatì", cimitero di via Tiepolo-San Massimo, Padova.

gest a fairly certain chronological placement. The types recognised as punctual comparisons, “*Situlen mit Hals und parallelseitigen Attaschen*” and “*Situlen mit Schullerrippen*” defined in 1991 by Prüssing, are framed in an intermediate phase of the Hallstatt horizon, certainly no later than the Ha C, i.e., during the 7th century BC.

The dating here proposed for the specimen is slightly earlier – but substantially in the same time span – than that formulated by Cupitò in 2004 according to the classification proposed by Renato Peroni for this type of *situlae*, defined as “Este Franchini type” and assigned to the Este IIIB2 horizon, i.e., between the last quarter of the 7th century BC and the first quarter of the 6th century BC (Peroni et al. 1975: fig. 11, 3).

Casa di Ricovero grave 236 in Este is set, on the basis of the grave goods, within the first half of the 8th century BC; the fragmentary *situla* defined here as Sit_6 from this tomb compares quite closely with a specimen from tomb 759 of the San Vitale cemetery in Bologna, assigned first by Müller Karpe and then by Pincelli and Morigi Govi to the second half of the 8th/early decades of the 7th century BC.

The dating referred to tomb 277 of the cemetery of Villa Benvenuti in Este and, therefore, *the terminus ante quem* for the dating of the related *situla* (Sit_3), – the Este IIC/IIIA passage, between the end of 8th and the beginning of the 7th – and that attributed to the type codified for the Slovenian area “*Eimer mit ungerippter Schulter*” with which it is compared, i.e. between the end of the Bronze Age and the Ha D2 horizon, may well overlap, especially considering the *longue durée* that characterises the type.

The Sit_5 type, consisting of specimens from the cemeteries of Este and Montebelluna, appears in Veneto area from the second half of the 7th century BC and persists throughout the 6th century BC, with a considerable success in the production of this type, highly represents especially in graves dated to the middle of the 6th century BC. Also in this case, the Veneto specimens and the corresponding Slovenian and Austrian attestations belong to the same chronological range.

In contrast to the specimens analysed so far, the *situla* of type Sit_2, used as ossuary in grave 236 of Casa di Ricovero cemetery in Este, finds comparisons with the *situlae* defined as “*nachfolger der Eimer von Typ Hajdüböszörmény*” by Prüssing, which were widespread in the northern Alpine area – mainly in the Austrian area – from the second quarter of the 7th century BC. The dating of grave 236 from Este, is fixed, as mentioned, within the first half of the 8th century BC, placing this exemplar in a chronological range significantly older than the totality of the transalpine specimens.

Regarding the specimens defined as “*unica*”, so without comparative artefacts and for which we therefore assume the chronology deduced from the relative literature, it is nevertheless possible to formulate a few stylistic and cultural reflections.

In detail, the Sit_unicum_A *situla* from the Rebato 187 grave in Este, presents a peculiar decoration of embossed dots and studs that cover almost the entire surface of the vessel. The decorative, geometric motif, which alternates rows of studs with repeated meanders made of very small dots, ends with hanging “L”, a typical motif common on pottery from the middle of the 8th century BC. The *situla* in exam is associated with the famous figurative lid with an animalistic frieze depicting animals such as an ox, ibex, ram and goat, followed by a wild beast with a paw in its jaws. The artefact, in which the concept of “domestic” and “wild”, of *chaos* and *kósmos* is

recalled, is considered among the precursors of the *Art of the Situle* in Este and is assigned to the end of the 7th century BC, 625-620 BC (Paltineri 2016: 130), a chronology certainly concordant with the entire assemblage of grave 187 (Alfonsi 1922: 46-47; Frey 1969: n.101, tab. 40-43; Turk 2005: 18; Gamba et al. 2013: 289; Paltineri 2016: 129-131).

The Sit_unicum_B *situla* from the Benvenuti 122 grave, dated to the late second half of the 7th century BC, represents a particular production among the bronze sheet vessels with geometric decoration of the Este panorama. The *situla*, with a predominantly embossed geometric covering decoration, shows alternating bands of meanders, dots, studs and concentric circles and, in the upper register, a continuous motif consisting of a sort of irregularly outlined triangles filled with dots and five stylised figures with a sinuous profile. In the literature, these silhouettes are interpreted as bird, a representation present and depicted, as well known, in various supports during Bronze and Iron Age in Veneto region and in Europe in general (Chieco Bianchi & Calzavara Capuis 1985: 274-276).

Benvenuti 122 *situla*, for whose shape and decoration no comparisons have been found in either Italic or European contexts, may nevertheless be subject to some specific observations.

As far as the overall decorative syntax of the vessel is concerned, there are a number of specific connections with artefacts found in the Austrian context, specifically from the cemetery of Kleinklein, in burials datable to the end of the 7th century BC. A specific decorative style is widespread in this area where figurations, geometric, animal and/or stylised human, are realised with small impressed dots and arranged in different registers; the decorated bands cover the entire surface of the support and often, are alternated with rows of studs surrounded by circles. This type of decoration is generally found on raised strings *cistae*.

There is a close agreement between the decoration on the Kleinklein *cistae* and that on the Benvenuti 122 *situla*: both on the Atestine *situla* and the *cistae* from Kleinklein, there is a geometric meander motif, followed by impressed studs surrounded by concentric circles; geometric fillers made of small dots are then present over the entire surface of the vase, leaving few or no empty spaces.

The figuration with stylised silhouettes presents in the Benvenuti 122 *situla* could be compared to the better-defined figures of grazing animals, perhaps deers, or to the same silhouettes of birds present in the Austrian *cistae*.

However, these specific motifs, realised in the Atestine *situla* giving just an approximative profile of a figure, could refer to the long tradition of the representation of the “branched N” motif on ceramic forms – mostly biconic-shape vessel and orcioli – widespread in the Villanovan area (Barbaro 2010: 104-118) but also in Veneto (Villamarzana and Frattesina) between the 10th and 9th centuries BC, accepting the possibility that a certain repertoire of decorative motifs could be revived and reformulated in different supports, generations after.

The stylistic proximity between the decorated Kleinklein-style *cistae* and the Atestine *situla*, in which it is nevertheless possible that a single decorative element is re-proposed from the Final Bronze Age tradition and inserted into a newly formulated syntax, suggests the possibility that there may have been a combination of elements from different traditions combined in a single artefact.

Turning to the sample of *cistae* analysed, a significant anteriority seems to emerge in the productions of Veneto area compared to the specimens identified as parallelisms, which came mainly from the Slovenian and Istrian areas. These exemplars showing in all cases a slight chronological shift compared to the Veneto artefacts. *Cista* from the Candeo 307 grave (Cist_1), dated in literature to Este IIIB2

¹¹ Associated with the *situla* is the well-known laminated bronze lid with a beardless grazing goat and a vegetal element inserted in a geometric syntax of meander and “wolf’s teeth”. This artefact is one of the main indicators of the assumption, around the middle of the 7th century BC, of elements from the Orientalising iconography in the Veneto figurative repertoire, according to the phenomenon recognised as “Orientalized Geometric”. For an in-depth examination of this topic see Paltineri 2016: 127-129 and cited bibliography.

Due to the stylistic characteristics stated, this artefact is not part of the sample here examined.

phase (late 7th-early 6th century BC), is close to specimens that appear in graves, both from the Italic and Slovenian area, dated from the middle of the 6th century BC onwards.

As described, a good comparison for “Tomba del Signore” cista, here “Cist_3”, came from Manching in Bavaria, although the *cista* was found among materials related to the La Tène phase of Manching oppidum and in the typology of C. Jacob this exemplar is considered stylistically close to specimens dated to the recent Hallstatt phase. In 2017, Cupitò well underlines the similarity between Rivoli Veronese “Tomba del Signore” cista, and Villa Benvenuti 277 cista, here “Cist_2”; although some structural differences lead to consider these two artefacts as different types, other general attributes allow us to state that the *cistae* are very close to each other, and, considering the grave goods in association with them, also in a chronological way – last decades of the 8th/beginning of the 7th century BC –.

The category of cups analysed here should, stylistically and chronologically, be considered within the large group defined in the Central European context as the “Beckentassen”. This class spread between the 8th and the 6th centuries BC in many European Hallstadian contexts and in the Italic peninsula; the typology here elaborated shows how the range of variability is high, even where some specimens can be grouped into very broad types. The most numerous comparisons for Veneto specimens can be found for type “Cup_1”, specifically for Variants “b” and “c”, both from the “Tomba dei Vasi Borchiatì” of Padova.

Relevant, on a chronological level, is the parallelism identified with the Salzburg-Maxglan grave 400 manufacture, datable, as the Padova grave, to a final moment of the 8th century BC. Then, both varieties find affinities with cups from the necropolis of Albate (Como), however, from burials datable to the 6th century BC. The other comparisons identified for the type specimens are mostly from the area of Bavaria and Salzburg, which can be attributed to the recent Hallstatt, phase Ha D1, middle of the 6th century BC.

It is clear that the type shows numerous attestations over a long period, certainly between the end of the 8th century BC, with the first attestations precisely in the area of Padova and Austria, to intensify during the 7th and the 6th centuries BC, maintaining certain specific morphological and decorative characteristics that make specimens with different chronologies continue to be typologically similar to each other.

As concerned the category of *lebetes*, for the type “Leb_2”, i.e., the specimen from grave 3 in Montebelluna-Posmon, a comparison has been identified, quite punctually, with a sporadic *lebetes* from the cemetery of Aislingen, Bayern, part of a type codified by Jacob 1995 and generically assigned to the Ha D phase (6th-early 5th century BC). The Posmon grave is dated between the end of the 7th century BC and the first decades of the 6th century BC.

Type “Leb_1”, on the other hand, consisting of two artefacts from the “Tombs dei Vasi Borchiatì” in Padova, has already been referred by Gamba and Gambacurta (Gamba et al. 2011: 76) to von Merhart’s type C “Becken der Gruppe C” (von Merhart 1952: Taf. 6, 7), in which, however, several examples with very different typological attributes converge, both in terms of decoration and shape of the attachments. Von Merhart’s Type C, therefore, has a very wide distribution, and the specimens are, however, globally attributed to the more recent Hallstatt phases. Gamba and Gambacurta report also that Padova *lebetes* represent the oldest attestation in Veneto region, but, a global reflection on the sample, suggests that these exemplars could be considered among the oldest of the type, considering the chronological attribution of “Tomba dei Vasi Borchiatì” to the end of the 8th century BC-beginning of the 7th BC.

In this perspective, in Egg’s 1985 work on tumulus graves in Hallstadian Austria (Egg 1985: 373-377), the scholar already specifies in a footnote how, compared to all other “Type C” specimens, the two *lebetes* from Padova are the oldest of the recognised attestations in Europe together with only one specimen from grave 600 in Hallstatt – with a non-punctual dating and generally attribute to

the middle of the 7th century BC – an aspect of absolute importance in the panorama of the circulation and assumption of these prestige objects linked to the ideology of the aristocratic banquet.

Conclusions

From the beginning, the identification of clearly codifiable types on the basis of specific attributes has appeared complex; indeed, the sample often answers to a logic of uniqueness rather than unity.

As is well known, bronze-sheet vessels and other artefacts related to drinking and eating in the aristocratic sphere represent goods of very high intrinsic value, prerogative of local élites and, specifically, of the apical figures of society.

The presence of a limited number of these artefacts is primary referable to their very high symbolic value, testifying the prestige of some single, aristocratic, graves. The problematic state of publication – as illustrated above – of a large part of the graves belonging to the chronological phases in exam certainly contributes significantly to the lack of documentation available to date.

As already mentioned, no punctual comparisons have always been found for the artefacts analysed to allow the formulation of an articulated typology; the category of artefacts examined represents, as previously discussed, a luxury good aimed at a certain segment of the community, and as such, shows limited attestations. This is especially evident for the 8th century BC, when the diffusion of metalware appears particularly circumscribed in space – in fact, it is almost exclusively attested in the centre of Este –; approaching the end of the century and with the beginning of the 7th century BC, new evidence are observed in Padova, Rivoli Veronese and finally, with the full 7th century, in Piave river Valley, precisely in Montebelluna-Posmon cemetery.

The real change of trajectory, however, is evident with the end of the 7th century BC, when a consistent and standardised production of a few types of *situlae*, *cistae*, cups and various artefacts related to the banquet is recorded, attest consistently throughout the 6th century BC, beside various and numerous new elaboration’s productions.

It is, however, possible to point out some specific cultural and chronological observations related to the deposition of bronze banquet vessels in the analysed graves.

In the most important burials dating to the 8th century BC (Casa di Ricovero 236, “Tomba del Signore” and “Tomba dei Vasi Borchiatì” graves), the deposition of bronze sheet vessels is associated with a rich grave equipment, representative of the rank/role of the deceased. In 236 Casa di Ricovero grave in Este it could be noted the highest expression of the self-representation of the role and rank of the deceased linked to specific status symbol manufactures that refer to different spheres of aristocratic power.

The bronze *situla* (here type Sit_2) is used as ossuary, the ashes are placed inside this container together with a sword and battle axe, both ritually broken, and the fragments, burnt, of a second *situla*, a *cista* and a bronze sheet set of drinking cups and cup-strainers. Placed outside the ossuary, a bronze craftsman-woodworker’s set – consisting of two files, a saw and an axe –, large knives – including one with an iron blade and bronze handle –, and other objects referring to the role of “adult male”, such as a lunate razor.

Very close, and unique among all the graves analysed, is the connection that emerges between the deceased and his very significant role in society, linked to multiple spheres: the warrior, the craftsman/possessor of raw materials, but also the ceremonial-convivial special participant – or maybe the bidder and the promoter itself – in the banquet, to drink and feasting together with the other members of the ruling élite. The bronze-sheet set acquires such a representative value for the deceased’s figure that it is placed on fire, probably directly on the funeral pyre, in the last act that the subject performs within his community, namely the funeral ceremony.

As mentioned, there are no comparisons for this ritual in any other case examined, for the two centuries in question; the closest

context – with the all the ritual relevant differences – to that of Casa di Ricovero 236 grave in Este is that of the “Tomba del Signore” of Rivoli, where a bronze-sheet banquet set is recorded, although is not defunct or exposed to the fire, as well as a warrior’s set, composed of offensive and defensive weapons, together with a horse track, a bit, to emphasise the rank of “horse-owner”.

It should therefore be emphasised that, in the 8th century BC burials, the association of weapons with bronze-sheet vessels is limited to the centres of Este (PD) and Rivoli Veronese (VR).

In the cemeteries of the other hegemonic centre in Veneto region, Padova, the deposition of offensive/defence weapons, in the strictest sense, is not attested; in the “Tomba dei Vasi Borchiatì”, in fact, there are two large knives – which could certainly also be weapons – but the traditional weapons symbolising hand-to-hand fighting, such as the sword or the lance, are absent.

The strong relationship between Este and its territory with the Villanovan sphere and tradition – where the deposition of weapons and metal vessels is well attested – has long been emphasised in literature, especially in the Bologna area (see, as example, the contemporary grave 39 in Benacci Caprara cemetery, Tovoli 1989: 128-144), in contrast to Padova, where the codes of self-representation

appear closer to the transalpine and central European world (above all Capuis 1993: 135-140; Capuis, Chieco Bianchi 2013: 59-64).

The observation of the bronze vessels here analysed shows that in Padova, besides the only attestation in an Iron Age grave of a Kurd-type *situla* – which undeniably finds its greatest expression and diffusion beyond the Alps – emerges, in the “Tomba dei Vasi Borchiatì”, the presence of the bronze *lebetes* as a banquet-related vessel. This type of vessel is completely absent in the Este landscape throughout the chronological span analysed.

As already mentioned, *lebetes*, used for boiling meat, found widespread distribution throughout Central and Eastern Europe, for a long chronological span, from the 7th to the 5th century BC (Marzatico 1998: 24), especially Von Merhart’s type C “with cross-shaped attachments”, in its many variants and varieties. According to a distributional analysis, the two *lebetes* from the “Tomba dei Vasi Borchiatì” in Padova represent the southernmost attestations (Fig. 9) but above all, the oldest of the type, which can be placed between the late 8th and the early 7th century BC.

This fundamental evidence suggests another possible trajectory of diffusion of this type of bronze-sheet vessels, from northern Italy through the Brenta and Piave river valleys – as witnessed by

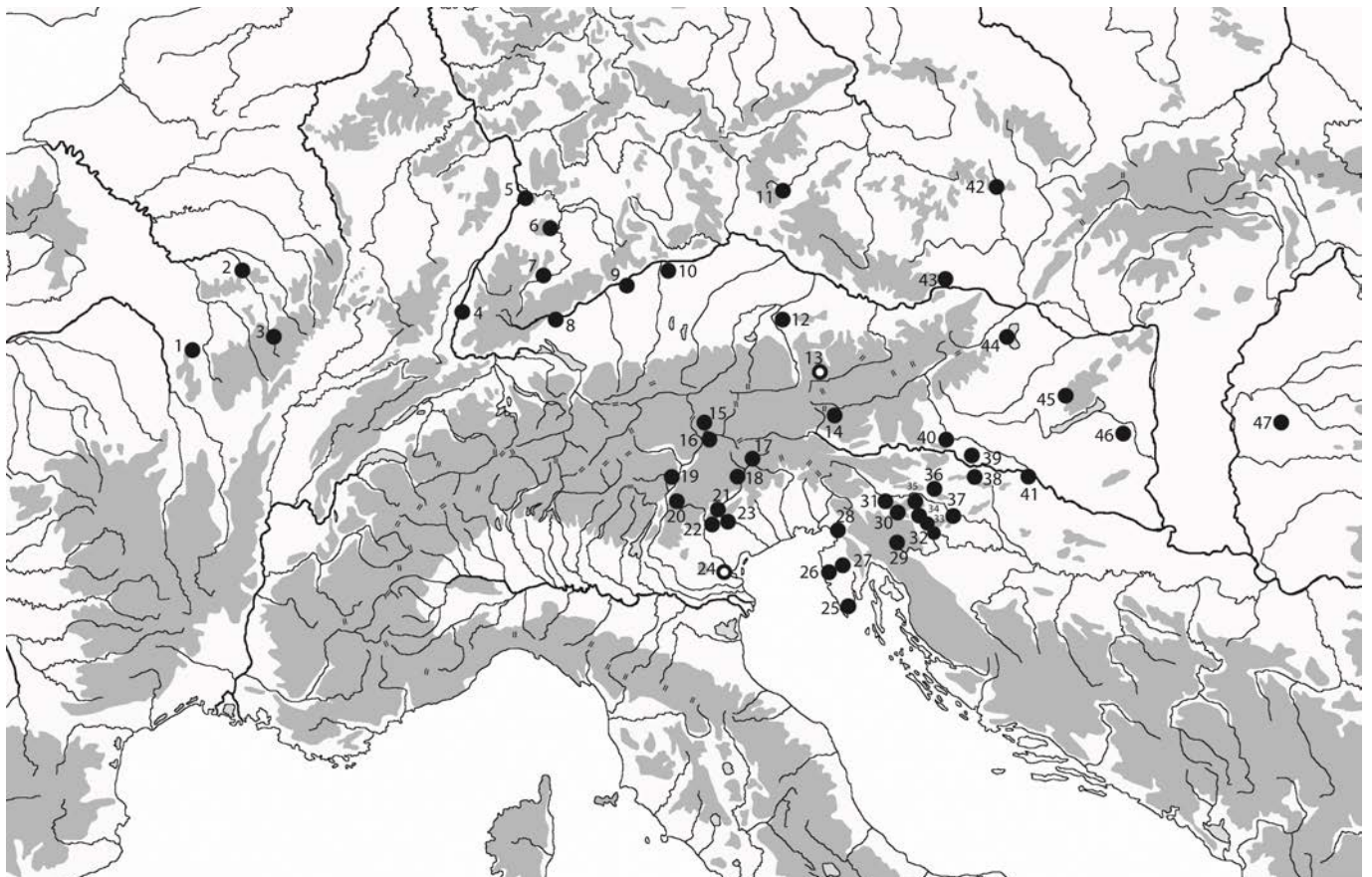

Fig. 9: Distribution map of cruciform attachments' *lebetes*, between 7th and 5th centuries BC (modified from Marzatico 1998: 24). Dots with a white core denotes the oldest attestations, between end of the 8th and by the middle of the 7th BC: 1. Cravant; 2. Buchères; 3. Poiseul-la-Ville; 4. Merdingen-Ihringen; 5. Friedrichsfeld; 6. Asperg; 7. Mössingen-Belsen; 8. Herberlingen-Hundersingen; 9. Aislingen; 10. Rehling; 11. Červené Poříčí-Svihov; 12. Helpfau-Uttendorf; 13. Hallstatt; 14. Ramingstein; 15. Niederassen/Rasun di Sotto; 16. Ellen; 17. Lozzo di Cadore; 18. Caverzano; 19. Sanzeno; 20. Castelnuovo; 21. Mel; 22. Asolo; 23. Montebelluna; 24. Padova; 25. Nesazio; 26. Picugi; 27. Beram; 28. Sveto; 29. Medvedjek; 30. Stična; 31. Magdalenska gora; 32. Dolenjske Toplice; 33. Šmarjeta; 34. Vintarjevec; 35. Vače; 36. Rifnik; 37. Libna; 38. Sv. Lovrenc; 39. Zamarkovi; 40. Kleinklein; 41. Sv. Petar Ludbreški; 42. Býčí skála grave; 43. Pfaffstetten; 44. Hof i. Leithagebirge; 45. Smolószölös; 46. Regöly; 47. Ártánd. / Carta di distribuzione dei lebeti con attacco a croce tra VII e V sec. a.C. (modificata da Marzatico 1998: 24). I punto con interno bianco indicano le attestazioni più antiche, tra la fine VIII sec. a.C. ed entro la metà del VIII sec. a.C.: 1. Cravant; 2. Buchères; 3. Poiseul-la-Ville; 4. Merdingen-Ihringen; 5. Friedrichsfeld; 6. Asperg; 7. Mössingen-Belsen; 8. Herberlingen-Hundersingen; 9. Aislingen; 10. Rehling; 11. Červené Poříčí-Svihov; 12. Helpfau-Uttendorf; 13. Hallstatt; 14. Ramingstein; 15. Niederassen/Rasun di Sotto; 16. Ellen; 17. Lozzo di Cadore; 18. Caverzano; 19. Sanzeno; 20. Castelnuovo; 21. Mel; 22. Asolo; 23. Montebelluna; 24. Padova; 25. Nesazio; 26. Picugi; 27. Beram; 28. Sveto; 29. Medvedjek; 30. Stična; 31. Magdalenska gora; 32. Dolenjske Toplice; 33. Šmarjeta; 34. Vintarjevec; 35. Vače; 36. Rifnik; 37. Libna; 38. Sv. Lovrenc; 39. Zamarkovi; 40. Kleinklein; 41. Sv. Petar Ludbreški; 42. Býčí skála grave; 43. Pfaffstetten; 44. Hof i. Leithagebirge; 45. Smolószölös; 46. Regöly; 47. Ártánd.

the attestations from Montebelluna and Cadore area – towards the centres beyond the Alps, where the type found particular success and diffusion.

Regarding a possible codification of bronze-sheet vessel types in the Veneto region, other artefacts have been identified, belonging to grave with generally older dates than those assigned to Central and Eastern European contexts, specifically the sample of raised strings *cistae* and the *situla* from grave 236 in Este, Casa di Ricovero cemetery. A deeper discussion is therefore necessary for these artefacts as well.

Firstly, we have to consider the possibility that in some grave a phenomenon of burial re-opening, already known in the literature for the Veneto area (see, above all, Bianchin Citton et al. 1998: 75-77), may have occurred in order to house a new, later deposition. In this regard, it is plausible that some more recent objects became part of the grave goods. However, this hypothesis does not seem valid at least for tomb 236 Casa di Ricovero, whose grave goods are absolutely chronologically consistent, and probably also for graves Candeco 307 and Rivoli.

Accordingly, the *situla* from the Casa di Ricovero 236 grave and the Candeco 307 and Rivoli Veronese *cistae*, if not subsequently added to an antecedent burial, could represent prototypes of artefacts produced in the Veneto area and later received in other territories, such as Bologna – in the case of the *cista* from the Certosa cemetery, comparable to the Candeco 307 one – and central Europe.

For the remainder of the sample, outcomes of the typological examination, the research of comparisons and the chronological analysis of the type, confirm the typological and chronological affinity with types already recognised in Central and Eastern European literature.

The analysis performed above clearly shows the possibility of reading the phenomenon of the codification and production of bronze sheet vessels in the examined area from a broader and more articulated point of view.

Even though the demonstrate import/assumption of “models” of metal vessels from the Central Europe to the Veneto area, as confirmed by the parallelisms and comparative chronologies identified, it seems possible to trace also an opposite trajectory, where some artefacts find their genesis and prototypes in Veneto region and then spread beyond the Alps. This phenomenon is expressed by the solid connections between Veneto and central Europe provided by the rivers Brenta and Adige and their valleys, but also by overland routes through Friuli Venezia Giulia towards the Balkan area. The panorama that come to light from these data is a more dynamic and synergic system of exchange and communication between these two strongly connected areas.

References

- AA.VV., 1976 - *Padova preromana*. Exhibition Catalogue, Nuovo Museo Civico agli Eremitani, 27th June-15th November 1976. Antoniana Edizioni, Padova, 307 pp.
- AA.VV., 1984 - *Preistoria del Caput Adriae*. Proceedings of the International Conference, Trieste, November, 19th and 20th, 1983. Comune di Trieste, Trieste, 188 pp.
- Alfonsi A., 1922 - *Este. Scoperte archeologiche nella necropoli atestina del nord, riconosciuta nel fondo Rebato*. Notizie degli Scavi di Antichità: 3-54.
- Aspes A., Bellintani P. & Fasani L., 1970 - I materiali della stazione protoveneta di Villamarzana, Rovigo, *Padusa* VI, 2-3: 37-54.
- Barbaro B., 2010 - *Inseparabili, aree funerarie ed entità territoriali in Etruria meridionale nel bronzo finale*. Grandi contesti e problemi della protostoria italiana, 14. All'Insegna del Giglio, Firenze, 367 pp.
- Belluzzo G. & Salzani L. (eds.) 1996, *Dalla Terra al Museo. Mostra di reperti preistorici e protostorici degli ultimi dieci anni di ricerca dal territorio veronese*. Exhibition Catalogue. Fondazione Fioroni, Legnago, 305.
- Bianchin Citton E., Gambacurta G. & Ruta Serafini A. (eds.), 1998 - ... “presso l'Adige ridente”. *Recenti rinvenimenti archeologici da Este a Montagnana*. Exhibition Catalogue. Adle, Padova, 446 pp.
- Bietti Sestieri A.M., 1976 - Rivoli Veronese. In: Aspes A., Rizzetto G. & Salzani L. (eds.), *3000 anni fa a Verona. Dalla fine dell'età del bronzo all'arrivo dei Romani nel territorio veronese*. Exhibition Catalogue. Museo Civico di storia naturale, Verona: 103-100.
- Capuis L., 1993 - *I Veneti. Società e cultura di un popolo nell'Italia Preromana*. Longanesi, Milano, 294 pp.
- Capuis L. & Chieco Bianchi A.M., 2006 - *Este II. La necropoli di Villa Benvenuti*. Monumenti Antichi dei Lincei, 64. Giorgio Bretschneider Editore, Roma, 536 pp.
- Capuis L. & Chieco Bianchi A.M., 2013 - Principi e aristocrazie. In: Gamba M., Gambacurta G., Ruta Serafini A., Tinè V. & Veronese F. (eds.), *Venetkens. Viaggio nella terra dei Veneti antichi*. Exhibition Catalogue. Marsilio, Venezia: 59-64.
- Cassola Guida P., 1978 - San Vito al Tagliamento (Pordenone). Una necropoli della prima età del ferro in località San Valentino, *Notizie degli Scavi di Antichità*: 5-55.
- Chieco Bianchi A.M. & Calzavara Capuis L., 1985 - *Este I. Le necropoli Casa di Ricovero, Casa Muletti Prosdocimi, Casa Alfonsi*. Monumenti Antichi dei Lincei, 51. Giorgio Bretschneider Editore, Roma, 511 pp.
- Colonna C., 2006 - *Necropoli dell'ultima età del bronzo nell'area padana. Per una loro cronologia relativa*. Accademia Lucchese di Scienze, Lettere e Arti, Fonti Archeologiche per la Protostoria Italiana, I. Edizioni S. Marco Litotipo, Lucca, 517 pp.
- Consonni A., 2008, L'abitato protostorico di Villamarzana (RO). Nuovi dati e spunti per un'analisi cronologica e territoriale. *Padusa* XLIV: 55-80.
- Cupitò M., 2004 - I materiali preromani di Borgo S. Croce. Revisione dei dati ottocenteschi e spunti interpretativi VIII e VII secolo a.C. *Quaderni di Archeologia del Veneto*, 20: 103-112.
- Cupitò M., 2017 - Ai limiti del mondo veneto. La “Tomba del Signore” di Rivoli Veronese. In: Cupitò M., Vidale M. & Angelini A. (eds.), *Beyond Limits. Studi in onore di Giovanni Leonardi*. Padova University Press, Padova: 511-530.
- de Marinis R.C., 2009 - Sesto Calende, la seconda tomba di guerriero. In: de Marinis R.C., Massa S. & Pizzo M. (eds.), *Alle origini di Varese e del suo territorio. Le collezioni del sistema archeologico provinciale*. Bibliotheca Archaeologica, 44. “L'Erma” di Bretschneider, Roma: 162-203.
- de Marinis R.C., 2016 - La necropoli protostorica di Albate. *Rivista Archeologica dell'antica Provincia e Diocesi di Como*, vol. 198: 5-46.
- de Min M., Gamba M., Gambacurta G. & Ruta Serafini A. (eds.), 2005 - *La città invisibile. Padova preromana. Trent'anni di scavi e ricerche*. Tipoarte, Bologna, 180 pp.
- De Stefani S., 1885 - Sopra la scoperta di oggetti di alta antichità scavati a Rivoli Veronese. *Atti del Regio Istituto Veneto di Scienze, Lettere ed Arti*, III, s. VI: 1764-1780.
- Dehn R., Egg M. & Lehnert R. 2005 - *Das Hallstattzeitliche Fürstengrab im Hügel 3 von Kappel am Rhein in Baden*. Monographien des Römisch-Germanisches Zentralmuseums Mainz, Band 63. Römisch-Germanisches Zentralmuseum, Mainz, 327 pp.
- Egg M., 1985 - Die hallstattzeitlichen Hügelgräber bei Helpfau-Utendorf in Oberösterreich. *Jahrbuch des Römisch-Germanisches Zentralmuseums*, 32: 323-393.
- Egg M. & Kramer D., 2016 - Die hallstattzeitlichen Fürstengrab von Kleinklein in der Steiermark: die beiden Hartnermichelkogel und der Pommerkogel. Monographien des Römisch-Germanisches Zentralmuseums Mainz, Band 125. Römisch-Germanisches Zentralmuseum, Mainz, 255 pp.
- Frey O.H., 1969 - *Die Entstehung der Situlenkunst: Studien zur figürlich verzierten Toreutik von Este*. De Gruyter, Berlin, 125 pp.
- Gamba M., Gambacurta G. & Ruta Serafini A. (eds.), 2014 - *La Prima Padova. Le necropoli di Palazzo Emo Capodilista-Tabacchi e di via Tiepolo-Via San Massimo tra il IX e l'VIII sec. a.C.* Regione Veneto, Venezia: 303 pp.

- Gamba M., Gambacurta G., Millo L. & Nardo A., 2011 - Per una revisione della tomba patavina "dei vasi borchiatì", *Archeologia Veneta*, XXIII: 44-115.
- Gamba M., Gambacurta G., Ruta Serafini A., Tinè V. & Veronese F. (eds.), 2013 - *Venetkens. Viaggio nella terra dei Veneti antichi*. Exhibition Catalogue. Marsilio, Venezia, 462 pp.
- Gambacurta G., 2011 - Altino preromana (VIII-IV sec. a.C.). In: Tirelli M. (ed.), *Altino Antica. Dai Veneti a Venezia*. Marsilio, Venezia: 57-60.
- Gedl M., 2001 - *Die Bronzegefäße in Polen*. Prähistorische Bronzefunde, II, 15. Franz Steiner Verlag, Stuttgart, 74 pp.
- laia C., 2005 - *Produzioni toreutiche della prima età del ferro in Italia centro-settentrionale: stili decorativi, circolazione, significato*. Biblioteca di Studi Etruschi, 40. Istituti editoriali e poligrafici internazionali, Roma, 311 pp.
- Jacob C., 1995 - *Metallgefäße der Bronze - und Hallstattzeit in Nordwest-, West- und Süddeutschland*. Prähistorische Bronzefunde, II, 9. Franz Steiner Verlag, Stuttgart, 238 pp.
- Jankovits K., 1996 - Beiträge zu der Situla und Bronzefanne mit Handgriff in Nordostitalien in der Spätbronzezeit. In: AA.VV., *Studien zur Metallindustrie im Karpatenbecken und den benachbarten Regionen*, Festschrift für Amália Mozsolics zum 85. Geburtstag. Budapest: 303-322.
- Jankovits K., 2017 - Kurd-Type Situlas: Evidence for Late Bronze Age Connections between the Carpathian Basin and Northern Italy. In: Kulcsár G. & Szabó G.V. (eds.), *State of the Hungarian Bronze Age research*. Proceedings of the Conference, December 2014. Robinco Kf., Budapest: 447-462.
- Jereb M., 2016 - *Die Bronzegefäße in Slowenien*. Prähistorische Bronzefunde, II, 19. Akademie der Wissenschaften und der Literatur, Mainz, 149 pp.
- Jockenhövel A., 1974 - Eine Bronzeamphore des 8. Jahrhunderts v. Chr. Von Gavelinghausen, Kr. Meschede (Sauerland). *Germania*, 52, 16-54.
- Kytlicová O. & Siegfried-Weiss A., 1991 - *Die Bronzegefäße in Böhmen*. Prähistorische Bronzefunde, II, 12. Franz Steiner Verlag, Stuttgart, 35 pp.
- Malnati L., 2002 - La Tomba 13 di Lovara di Villabartolomea. In: Aspes A. (ed.), *Preistoria veronese. Contributi e aggiornamenti*. Memorie del Museo Civico di storia naturale di Verona, Verona, II, 5: 175.
- Manessi P. & Nascimbene A., 2003 - *Montebelluna. Sepolture preromane dalle necropoli di Santa Maria in Colle e Posmon*. Museo di Storia Naturale e Archeologia, Sommacampagna, 352 pp.
- Martin J., 2009 - *Die Bronzegefäße in Mecklenburg-Vorpommern, Brandenburg, Berlin, Sachsen-Anhalt, Thüringen und Sachsen*. Prähistorische Bronzefunde, II, 16. Franz Steiner Verlag, Stuttgart, 180 pp.
- Marzatico F., 1998 - Recipienti preromani in lega di rame (bronzo) dal territorio atestino. In: Raffaelli U. (ed.), *Rame d'arte. Dalla preistoria al XX secolo nella Alpi centro-orientali*. Exhibition Catalogue. Provincia Autonoma di Trento, Trento: 13-36.
- Morigi Govi C. 1976 - La prima età del ferro nell'Emilia e Romagna. *Atti della XIX Riunione Scientifica dell'Istituto Italiano di Preistoria e Protostoria, in Emilia e Romagna, October, 11th-14th, 1975*. Istituto Italiano di Preistoria e Protostoria, Firenze: 163-180.
- Novotná M., 1991 - *Die Bronzegefäße in der Slowakei*. Prähistorische Bronzefunde, II, 11. Franz Steiner Verlag, Stuttgart, 85 pp.
- Pacciarelli M., 2010 - *Dal villaggio alla città: la svolta protourbana del 1000 a. C. nell'Italia tirrenica*. Grandi contesti e problemi della protostoria italiana, 4. All'insegna del giglio, Firenze, 311 pp.
- Paltineri S., 2016 - I linguaggi figurativi di età orientalizzante in Veneto: alcune note. In: Bonetto J., Busana M.S., Giotto R.A., Salvadori M. & Zanovello P. (eds.), *I mille volti del passato. Studi in onore di Francesca Ghedini*. Edizioni Quasar, Roma: 123-134.
- Patay P. & Petres E.F., 1990 - *Die Bronzegefäße in Ungarn*. Prähistorische Bronzefunde, II, 10. C.H. Beck'sche Verlagsbuchhandlung, München, 109 pp.
- Peroni R., 1973 - *Studi di cronologia hallstattiana*. De Luca, Roma 1973, 81 pp.
- Peroni R., Carancini G. L., Coretti Irdi P., Ponzi Bonomi L., Rallo A., Saronio Masolo P. & Serra Ridgway F. R., 1975 - *Studi sulla cronologia delle civiltà di Este e Golasecca*. Origines. Sansoni, Firenze, 410 pp.
- Peroni R., 1994 - *Introduzione alla protostoria italiana*. Laterza, Roma, 329 pp.
- Peroni R., 1998 - Classificazione tipologica, seriazione cronologica, distribuzione geografica. *Aquileia Nostra*, LXIX: 10-28.
- Pincelli R. & Morigi Govi C. (eds.), 1976 - *La necropoli villanoviana di San Vitale*. Istituto per la storia di Bologna, Bologna, 586 pp.
- Pirazzini C., 2005 - Tomba 318. In: De Min M., Gamba M., Gambacurta G. & Ruta Serafini A. (a cura di), *La città invisibile. Padova preromana. Trent'anni di scavi e ricerche*. Edizioni Tipoarte, Bologna: 157.
- Prüssing G., 1991 - *Die Bronzegefäße in Österreich*. Prähistorische Bronzefunde, II, 11. Franz Steiner Verlag, Stuttgart, 117 pp.
- Salzani L., 1976 - Risultati della prima campagna di scavo nell'insediamento protoveneto di Villamarzana, *Padusa XII*: 13-39.
- Salzani L., 1983 - Colognola ai Colli. In: Salzani L. (ed.), *Colognola ai Colli*. Indagini archeologiche. "La Grafica", Verona: 31-33.
- Salzani L., 1984 - La necropoli di Garda (Verona). *Bollettino del Museo Civico di Storia Naturale di Verona*, XI: 113-148.
- Salzani L., 2001 - Tombe protostoriche dalla necropoli della Colombara (Gazzo Veronese). *Padusa*, XXXVII: 83-132.
- Salzani L., 2005 - La necropoli protostorica di Ponte Nuovo a Gazzo Veronese, *Notizie Archeologiche Bergomensi*, 13: 7-111.
- Salzani L., 2018 - *Necropoli dei Veneti Antichi a Ca' del Ferro di Oppeano (Verona)*. SAP Società Archeologica, Sandrigo, 192 pp.
- Salzani L. & Consonni A., 2005 - L'abitato protostorico di Villamarzana-Campagna Michela (RO). *Scavi 1993, Padusa XLI*: 7-55.
- Sassatelli G., 2013 - L'Arte delle situle. In: Gamba M., Gambacurta G., Ruta Serafini A., Tinè V. & Veronese F. (eds.), *Venetkens. Viaggio nella terra dei Veneti antichi*. Exhibition Catalogue. Marsilio, Venezia: 99-105.
- Schäfer D., 2019 - Ein reich ausgestattetes Grab der älteren Hallstattzeit aus Salzburg-Maxgalln. In: Baitinger H. & Schönfelder (eds.), *Hallstatt und Italien*. Römisch-Germanisches Zentralmuseum, Mainz: 171-194.
- Stjernquist B., 1967 - *Ciste a cordoni (Rippenzisten): Produktion, Funktion, Diffusion*. Acta archeologica Lundensia. 6.4. Lund Habelt, Bonn, 199 pp.
- Tarbay G. J., 2018 - Looted Warriors from Eastern Europe. *Dissertationes Archaeologicae*, ser. 3, n. 6: 313-360.
- Tovoli S. (ed.), 1989 - *Il sepolcreto villanoviano Benacci Caprara di Bologna*. Grafis, Bologna, 440 pp.
- Turk P. (ed.), 2005 - *Images of Life and Myth*. Exhibition Catalogue. Narodni Muzej Slovenije, Ljubljana, 80 pp.
- Vitri S., 1996 - Montereale Valcellina. Necropoli in Località Dominu. I materiali. In: Malnati L., Croce da Villa P., Di Filippo Balestrazzi E. (eds.), *La Protostoria tra Sile e Tagliamento. Antiche genti tra Veneto e Friuli*. Esedra, Padova: 457-459.
- von Merhart G. 1952 - Studien über einige Gattungen von Bronzegefäßen, in *Festschrift des R. - G. Zentralmuseums in Mainz*, II. Römisch-Germanisches Zentralmuseum, Mainz: 1-71.
- Zampieri G., 1975 - Necropoli paleoveneta di via Leonardo Loredan. *Bollettino del Museo Civico di Padova*, LXIV: 15-191.